



Faceplate backing plate installation

AC01322 / 29" x 44" or AC01332 / 29" x 50"

Bottom faceplate backing plate installation

AC01321 / 44" x 6" or AC01333 / 50" x 6"

Projection kit installation

AC01323 / 2" or 4"*

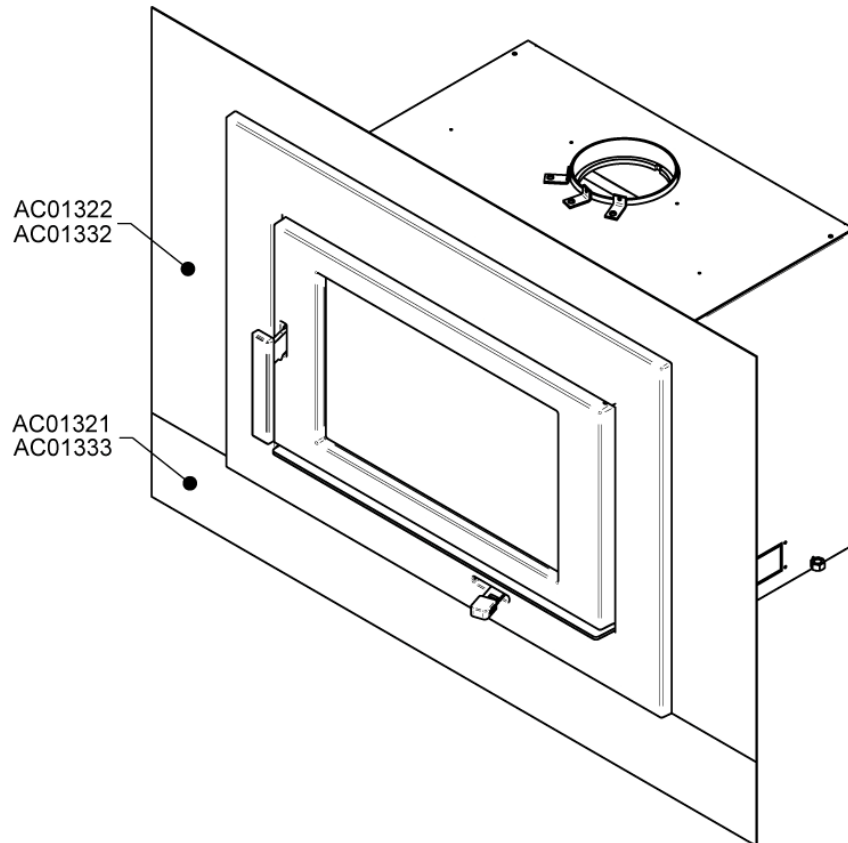

- Prior to the installation of the faceplate backing plate, measure the projection of the cast iron faceplate to the front of the fireplace opening. This will determine its location on the convection air jacket of the insert.
- If the projection is greater than 0", a projection kit AC01323 will need to be used before the installation of the cast iron faceplate. See **step 3**.

***Note that in order to install the optional projection kit AC01323, one of the optional faceplate backing plate kit AC01322 or AC01332 must be purchased separately to secure the projection kit to it.**

Step 1: Support brackets installation

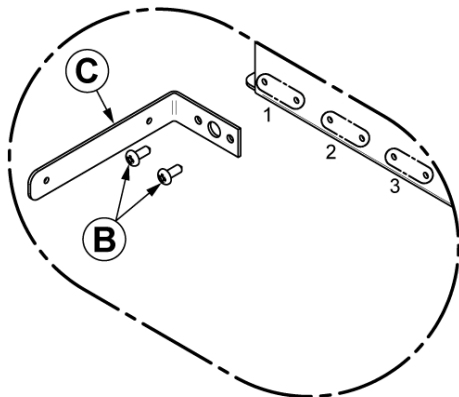
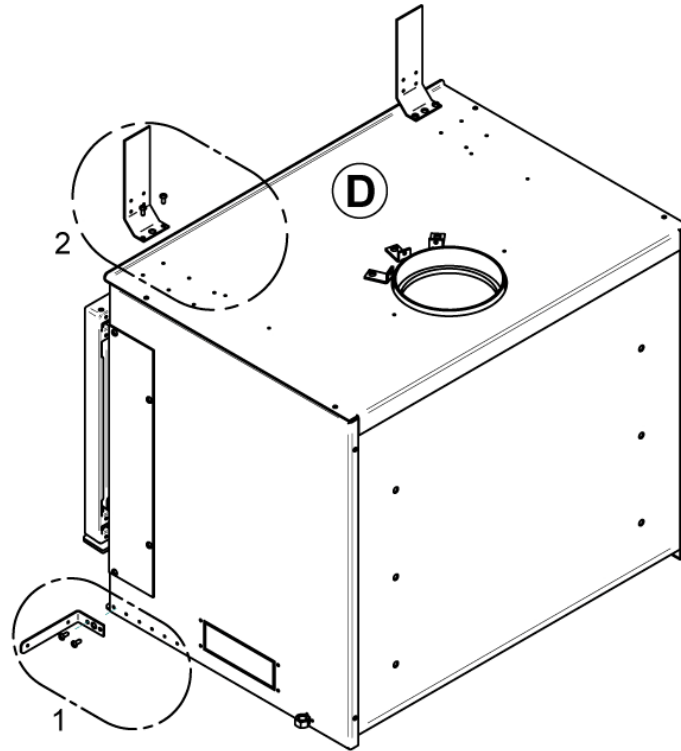

DETAIL 1

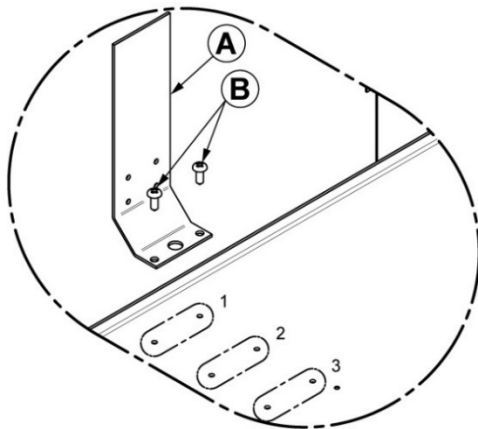

DETAIL 2

- 1.1. Position the insert in its final location in order to measure the projection of the cast iron faceplate from the front of the fireplace finish.
- 1.2. Secure the mounting brackets **(C)** (see DETAIL 1) on each side and **(A)** (see DETAIL 2) on the top of the convection air jacket **(D)** with screws **(B)**.

The location of the predrilled holes in the convection air jacket are to identify the following projections:

- 1- The cast iron faceplate has **no projection (0")** from the front of the fireplace finish.
- 2- The cast iron faceplate has a **2" projection** from the front of the fireplace finish.
- 3- The cast iron faceplate has a **4" projection** from the front of the fireplace finish.



To avoid overheating, it is not allowed to add or change the location of the existing holes.

Step 2: Faceplate backing plate installation

2.1. Faceplate backing plate installation AC01322 and AC01332

- Align the holes in the panel (E) with the outer holes of the brackets (A) and the outer hole of the brackets (C) and secure with ten screws (B).

2.2. Bottom faceplate backing plate installation AC01321 and AC01333

- Align the holes in the panel (F) with the inner holes of the brackets (C) and secure with two screws (B).

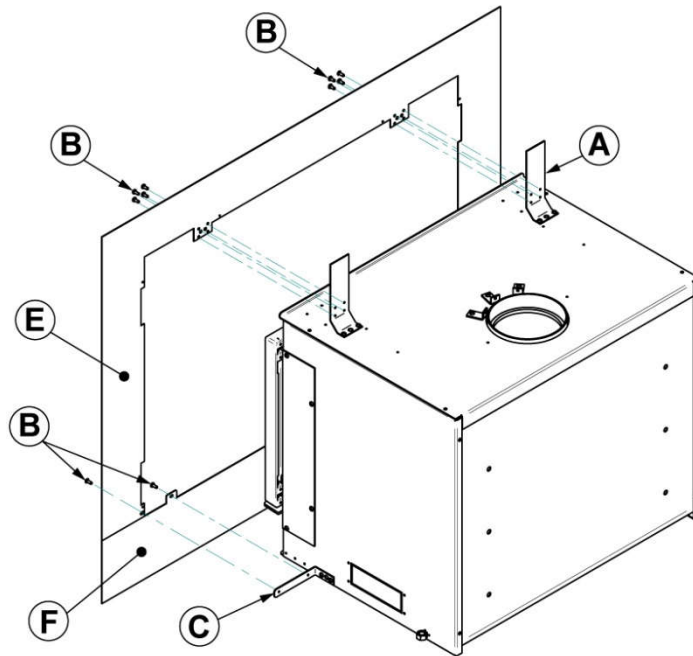

Note: If your installation requires the addition of a projection kit AC01323, go to **step 3**. Otherwise, go to **step 4**.

Step 3: Projection kit installation AC01323 / 2" or 4"

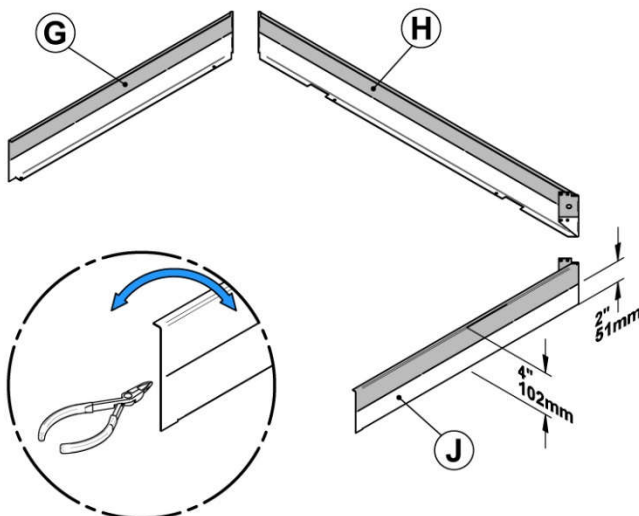

For a 4" projection, go directly to step 3.2

3.1. For a 2" projection:

- Fold each part (G), (H) and (J) on the axis of the micro joints to separate them into two 2" section.
- Discard the top portion (grey) and keep the bottom portion of each piece to complete the assembly.

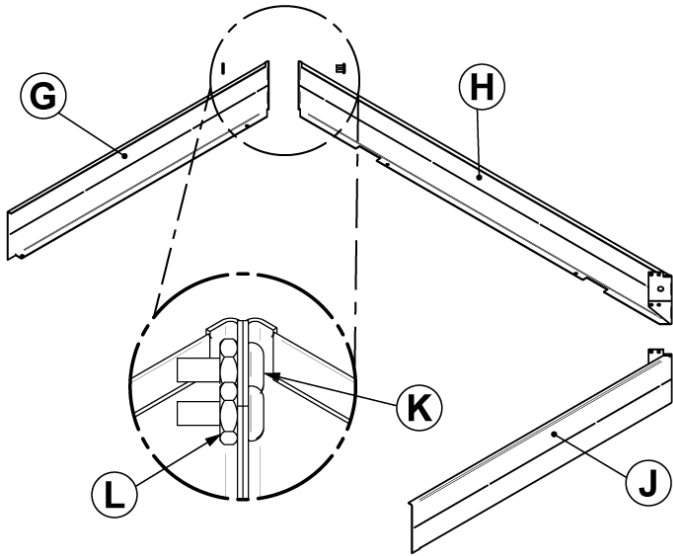

3.2. Projection kit assembly (4" projection shown)

- Secure the side projection (**G**) to the top projection (**H**) by the means of two bolts (**K**) and two nuts (**L**). Repeat this procedure for the assembly on the other side (**J**).

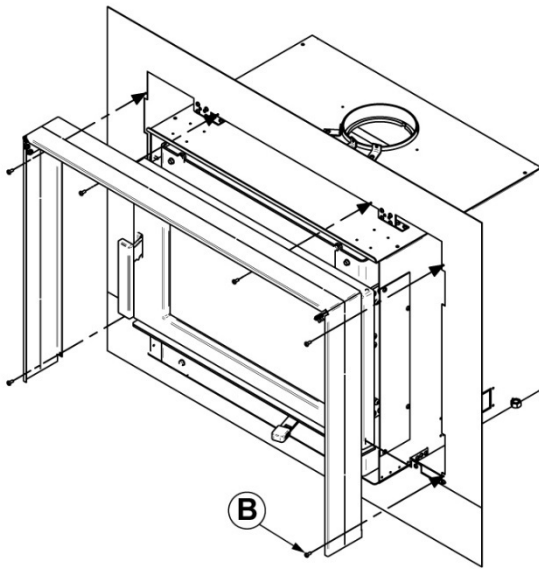

3.3. Projection kit installation

- Align the holes inside the projection kit assembly with the corresponding holes on the faceplate backing plate and fasten with 6 screws (**B**).

Step 4 : Cast iron faceplate installation

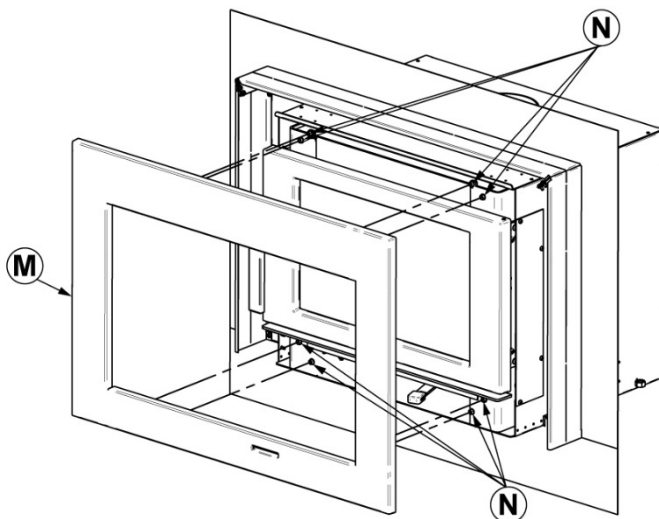

Finalize the positioning of the wood insert so that the faceplate backing plate leans against the fireplace's front finish. Then refer to the manual supplied with your heater to install the cast iron components (**M**) using screws (**N**) pre-installed on the front of the firebox of the insert.