



MODEL OSBURN STRATFORD

Installation Instructions

This installation manual will help you obtain a safe, efficient, dependable installation for your fireplace and chimney system. Please read and understand these installation instructions before beginning your installation.

CAUTION: Do not attempt to modify or alter the construction of the fireplace or its components. Any modification or alteration of construction may void the warranty, listings and approvals of this system. In that case, Stove Builder International (SBI) will not be responsible for damages. Install the fireplace only as described in these instructions.

**PLEASE RETAIN THIS MANUAL
FOR FUTURE REFERENCE**

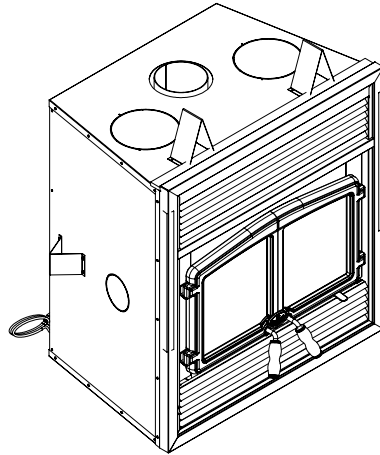

Listed to standards ULC-S610 and UL-127

Manufactured by:

Stove Builder International Inc.

STOVE BUILDER INTERNATIONAL INC.

1700 Leon-Harmel Street, Quebec City, Quebec, Canada, G1N 4R9 Tel.: (418) 527-3060

TABLE OF CONTENTS

Page

1.	SAFETY RULES FOR OPERATING YOUR FIREPLACE	1
2.	CERTIFICATION LABEL	2
3.	THE FIREPLACE	3
3.1	INTRODUCTION	3
3.1.1	Parts Required	3
3.1.2	Additional Equipment (optional)	3
3.2	OPERATING THE OSBURN <i>STRATFORD</i>	4
3.2.1	Fuel.....	4
3.2.2	The use of manufactured logs	4
3.2.3	First Fires	4
3.2.4	Building a Fire.....	5
3.2.5	Maintaining the Fire	5
3.2.6	Primary Air.....	6
3.2.7	Combustion Settings	6
3.2.8	Smoking – Causes and Troubleshooting.....	7
3.3	MAINTAINING YOUR OSBURN <i>STRATFORD</i>	9
3.3.1	Creosote.....	9
3.3.2	Chimney Maintenance	9
3.3.3	Top Baffle Removal Prior to Cleaning the Chimney.....	9
3.3.4	Dealing with a Chimney Fire	10
3.3.5	Plated Finish Maintenance	10
3.3.6	Ashes	10
3.3.7	Refractory Replacement.....	11
3.3.8	Glass Care – Replacement	11
3.3.9	Glass Care – Cleaning	11
3.3.10	Gasket Replacement.....	11
3.4	FIREPLACE INSTALLATION	12
3.4.1	Locating the OSBURN <i>STRATFORD</i>	12
3.4.2	Heart Extension Requirements.....	12
3.4.3	Framing, Facing, Mantel, and Combustible Shelf	13
3.5	HOT AIR DUCTING INSTALLATION	17
3.5.1	Gravity Kit	17
3.5.2	Central Forced Air Kit (Not tested under EPA certification)	19
3.6	FRESH AIR KIT (Optional)	21
3.6.1	Outside Air Installation.....	21
3.7	DOOR OVERLAY INSTALLATION	22
4.	THE CHIMNEY	23
4.1	CHIMNEY INSTALLATION NOTES	23

4.2	CHIMNEY INSTALLATION INSTRUCTIONS.....	24
4.3	OFFSET CHIMNEY INSTALLATION.....	26
4.4	ANGLED WALL RADIATION SHIELD	29
4.5	CHIMNEY SUPPORT INSTALLATION.....	30
4.6	CHIMNEY CHASE AND MULTIPLE TERMINATIONS	30
4.7	INSTALLATION INSTRUCTIONS FOR MASONRY APPLICATION.....	32
5.	OPTIONS	33
6.	APPENDIX	34
7.	OSBURN LIMITED LIFETIME WARRANTY.....	35

1. SAFETY RULES FOR OPERATING YOUR FIREPLACE

- Use only an Osburn glass door, specifically designed for the model Osburn *Stratford*.
- When cleaning the fireplace, the ashes should be placed in a metal container with a tight fitting lid. The closed container of ashes should be placed on a non-combustible floor or on the ground outside the house, pending final disposal. If the ashes are disposed of by burial in soil or otherwise locally dispersed, they should be retained in the closed container until all cinders have thoroughly cooled.

CAUTION: Never use gasoline, kerosene, charcoal lighter fluid or similar liquids to start or rekindle a fire in this fireplace. Keep all such liquids well away from the fireplace at all times.

CAUTION: Keep combustible materials at least 48 inches away from the front of the fireplace opening.

CAUTION: Never leave children unattended when there is a fire burning in the fireplace.

CAUTION: Never use grate or elevate fire. Build wood fire directly on hearth.

CAUTION: Do not use a fireplace insert and other products not specified for use with this fireplace.

WARNING: THIS FIREPLACE HAS NOT BEEN TESTED WITH AN UNVENTED OR VENTED GAS LOG SET. TO REDUCE RISK OF FIRE OR INJURY, DO NOT INSTALL AN UNVENTED GAS LOG SET INTO THIS FIREPLACE.

PLEASE NOTE THAT THE PICTURES SHOWN IN THIS MANUAL ARE GENERIC AND MAY NOT MATCH EXACTLY THE LOOK OF YOUR FIREPLACE.

REGISTER YOUR WARRANTY ONLINE

To receive full warranty coverage, you will need to show evidence of the date you purchased your unit. Keep your sales invoice. We also recommend that you register your warranty online at www.osburn-mgf.com/ Registering your warranty online will help us track rapidly the information we need on your unit.

2. CERTIFICATION LABEL



STANDARDS / NORME D'ESSAI:
CAN/ULC-S610-M87
UL 127-1999
(NOV. 2006)

LISTED FACTORY BUILT FIREPLACE

FOYER PRÉFABRIQUÉ HOMOLOGUÉ

MODEL / MODÈLE :
STRATFORD

Serial Number
No. de Série **1**

FOR USE WITH
WOOD ONLY

POUR UTILISATION AVEC
BOIS SEULEMENT

CONTACT LOCAL BUILDING OFFICIALS ABOUT THE
RESTRICTIONS AND INSTALLATION INSPECTION IN
YOUR AREA.
COMMUNIQUER AVEC LES AUTORITÉS LOCALES DU
BÂTIMENT ET DE LA PRÉVENTION DES INCENDIES AU
SUIET DES RESTRICTIONS D'INSTALLATION DANS
VOTRE SECTEUR.

INSTALL AND USE ONLY IN ACCORDANCE WITH SBI STOVE BUILDER INTERNATIONAL INSTALLATION AND OPERATION INSTRUCTIONS.

L'INSTALLATION ET L'OPERATION DOIT SE FAIRE SELON LES INSTRUCTIONS D'INSTALLATION ET D'UTILISATION DE SBI FABRICANT DE POÊLES INTERNATIONAL.

PREVENT HOUSE FIRES

- Burn solid wood only.
- For safety, keep doors tightly closed.
- Do not overfire unit.
- Appropriate for outside installation.
- Replace glass only with ROBAX 5mm thick.
- For more information, refer to owner's manual.

PRÉVENEZ LES INCENDIES

- Brûler du bois massif seulement.
- Pour votre sécurité, maintenir les portes fermées de façon étanche.
- Ne pas surchauffer le foyer.
- Convient pour installation à l'extérieur.
- Remplacer la vitre seulement avec un verre ROBAX de 5mm d'épaisseur.
- Pour de plus amples renseignements, référez-vous au manuel d'instructions.

MINIMUM CLEARANCES TO COMBUSTIBLE MATERIALS

Sidewall : **17 in (432 mm)**
Mantle (From floor) * : **50 in (1270 mm)**
Back Wall : **0 in (0 mm)**
Side facing * : **0 in (0 mm)**

DÉGAGEMENTS MINIMUM AUX MATÉRIAUX COMBUSTIBLES

Mur latéral : **17 po (432 mm)**
Poutre (du sol) * : **50 po (1270 mm)**
Mur Arrière : **0 po (0 mm)**
Parement latéral * : **0 po (0 mm)**

* Subject to a maximum depth. Consult owner's manual.

* Sujet à une profondeur maximum. Consulter le manuel du propriétaire.

Blower / Ventilateur: EBMPAPST MOD.QLN 65/0012 A15-2524L-91, 115V., 60Hz., 39W.

PROCEDURE TO FOLLOW IN CASE OF RUN-AWAY FIRE

- 1) Keep doors closed
- 2) Close all combustion air controls

EN CAS D'INCENDIE DE CHEMINÉE

- 1) Maintenir les portes fermées
- 3) Fermer tous les dispositifs d'admission d'air

U.S. ENVIRONMENTAL PROTECTION AGENCY (EPA). CERTIFIED TO COMPLY WITH JULY, 1990 PARTICULATE EMISSION STANDARDS. PHASE II
AGENCE DE PROTECTION DE L'ENVIRONNEMENT DES É.-U. (EPA). CONFORME AUX STANDARDS D'ÉMISSIONS DE PARTICULES DE JUILLET 1990, PHASE II.

CAUTION

- HOT WHILE IN OPERATION.
- DO NOT TOUCH. KEEP CHILDREN, CLOTHING AND FURNITURE AWAY.
- CONTACT MAY CAUSE SKIN BURNS. SEE NAME-PLATE AND INSTRUCTIONS.

ATTENTION

- CHAUD EN FONCTIONNEMENT.
- NE PAS TOUCHER. GARDER LES ENFANTS, LES VÊTEMENTS ET LES MEUBLES ÉLOIGNÉS.
- UN CONTACT AVEC LA PEAU PEUT OCCASIONNER DES BRÛLURES. VOIR LES INSTRUCTIONS.

Made in Québec (Québec), Canada
01/03/2007 (# test)

Fabriqué à Québec (Québec), Canada
01/03/2007 (# test)

27012

3. THE FIREPLACE

3.1 INTRODUCTION

The OSBURN *STRATFORD* fireplace is an energy efficient, heat circulating, close combustion fireplace. You will receive a lifetime of comfort and enjoyment from your fireplace provided it is installed, maintained and operated properly.

- Please read these instructions and retain this manual for future reference.
- Before beginning the fireplace installation, consult the local authorities to obtain your building permit and check your local building codes. Install the fireplace only as described in these instructions and using only components from the manufacturers listed in table 2.
- The OSBURN *STRATFORD* is not intended for use with a gas log. Failure to follow these instructions will void the certification and the warranty of the fireplace and may result in an unsafe installation.

3.1.1 Parts Required

- Fireplace model OSBURN *STRATFORD*
- Insulated chimney made by the manufacturers listed in table 2, with the corresponding specifications :
 - Chimney lengths
 - Elbows (where necessary)
 - Associated components as per these installation instructions.

3.1.2 Additional Equipment (optional)

- Forced air kit
- Gravity venting system
- Outside air kit
- Fireguard

3.2 OPERATING THE OSBURN STRATFORD

3.2.1 Fuel

The OSBURN *STRATFORD* is designed to work best when fuelled with seasoned cordwood. Hardwoods are preferred to softwoods since the energy content of wood is relative to its density. Hardwoods will result in a longer burning fire and less frequent refuelling. A moisture content of 15% to 20% (seasoned) is recommended. Wood that has been cut and split and let to dry under a cover for a period of one year will usually meet that criteria. Excessively wet wood will be difficult to burn and will result in lower efficiency, increased creosoting and deposits on the glass and in the chimney. Excessively dry wood will burn well but will also have higher emissions and shorter burning time.

Do not burn scrap or garbage, treated wood or wood such as driftwood from the ocean which has been exposed to salt or other chemicals. Salt or chemicals can corrode the firebox and chimney. Do not burn large amounts of paper, cardboard, Christmas tree branches or building construction materials. Intense firing with these materials may overheat the fireplace, causing damage to the unit, a fire or even possibly igniting a chimney fire if the chimney is creosoted.

3.2.2 The use of manufactured logs

There are numerous types of manufactured logs sold on the market. You must be very careful with this type of product. Many brands of manufactured logs contain chemical additives. **DO NOT BURN ANY MANUFACTURED LOGS CONTAINING CHEMICAL ADDITIVES.** If you do, you may overheat your fireplace, therefore causing a fire hazard and voiding your warranty. Logs containing chemical additives burn a lot hotter and were designed for decorative fireplaces. Decorative fireplaces generally have larger, cooler, and less air-tight fireboxes. Your OSBURN *STRATFORD*, on the other hand, has a smaller, completely sealed firebox which attains much higher temperatures. It is therefore not designed to support excessive heat caused by the addition of chemicals in manufactured logs. Manufactured logs made of 100% wood residues do not pose a threat to your fireplace. However, they must be used carefully. Manufactured logs typically release a much larger heat output over a short period of time. Therefore, you cannot place a large quantity of such logs into your fireplace. Start with one log, and gradually increase the load. Never put more than 4 logs. The logs should be of an average size and not exceed 8 inches in diameter.

3.2.3 First Fires

The fresh paint on your fireplace needs to be cured to preserve its quality. Once the fuel load is properly ignited, only burn small fires in your fireplace for the first four hours of operation. Never open the air control more than necessary to achieve a medium burn rate. Make sure that there is enough air circulation while curing the stove. Open one or more windows. The odours can be smelled during the 3 or 4 first fires.

3.2.4 Building a Fire

To start a fire, place several crumpled up balls of newspaper in the firebox. Place small dry pieces of kindling on top of the paper, criss-crossing the kindling so that there are air spaces in between. Keep the fuel far back enough so that air can get underneath. Open the air controls fully and light the newspaper. Once the newspaper and the kindling is well ignited, close the door. Once the kindling fire is well established, cordwood can be added. (See Primary Air Combustion Control section for proper operation of the air controls.)

The unit will burn best with 2-3 pieces of cordwood spaced 1 to 2 inches apart and allowing air to get under the fuel. Criss-crossing or arranging the fuel so that air can get underneath, will help the fire to get started easily. The unit should be operated with the air control fully open long enough to get the cordwood well ignited

3.2.5 Maintaining the Fire

Once the wood has been consumed (or partially consumed) and you have obtained a good bed of embers, you should reload the unit. In order to do so, open the air control to its maximum for approximately 15 seconds prior to opening the fireplace door. Then, proceed by opening the door very slowly. Open it by 2" to 4" (52 to 104 mm) for 10 seconds before opening it completely. This procedure will increase the draft and thus eliminate the smoke which is stagnant in a state of slow combustion in the fireplace. Then, bring the red embers to the front of the stove and reload the unit.

Your OSBURN *STRATFORD* fireplace will work best if a thick bed of hot embers is maintained in the bottom of the firebox, and a minimum of two large pieces of seasoned fuel are added. Combustion efficiency is largely related to establishing a hot ember bed, and hot firebox temperatures. The quicker the fireplace and chimney (flue) get up to normal operating temperatures, the better. A small intense fire is preferred to a large smouldering fire, both to improve combustion efficiency and to reduce the amount of creosote build-up. The best performance will be obtained by adding relatively small amounts of fuel to a well established ember bed, and then operating with the air inlet control open long enough to achieve a hot fire. Use a poker to make an air channel in the embers below the wood. This will allow air to flow under the wood for a more efficient burn. Once you have reached the desired temperature, the primary air can be set to a medium setting. You know you have reached the desired temperature when, closing the primary air control, you can see a flame at the top of the firebox. The benefit of this technique will be cleaner glass, less creosoting, greater efficiency and the most pleasing fire for your enjoyment.

3.2.6 Primary Air

There is no flue damper in the OSBURN *STRATFORD*. As in common with air tight stoves, the combustion air control sets the flow of air entering the firebox. This allows for a more precise control of the fire. The combustion air control is located below the door on the right side. The main source of air (primary air) entering the firebox can be diminished by moving the air combustion control from right to left. The primary air is fully opened when the air control is completely moved to the right. The combustion air control should be in the closed position (primary air) when the fireplace is not in use. This will minimize air leakage up the chimney. The combustion air control should be opened before opening the door to minimize the possibility of back draft coming into the room.

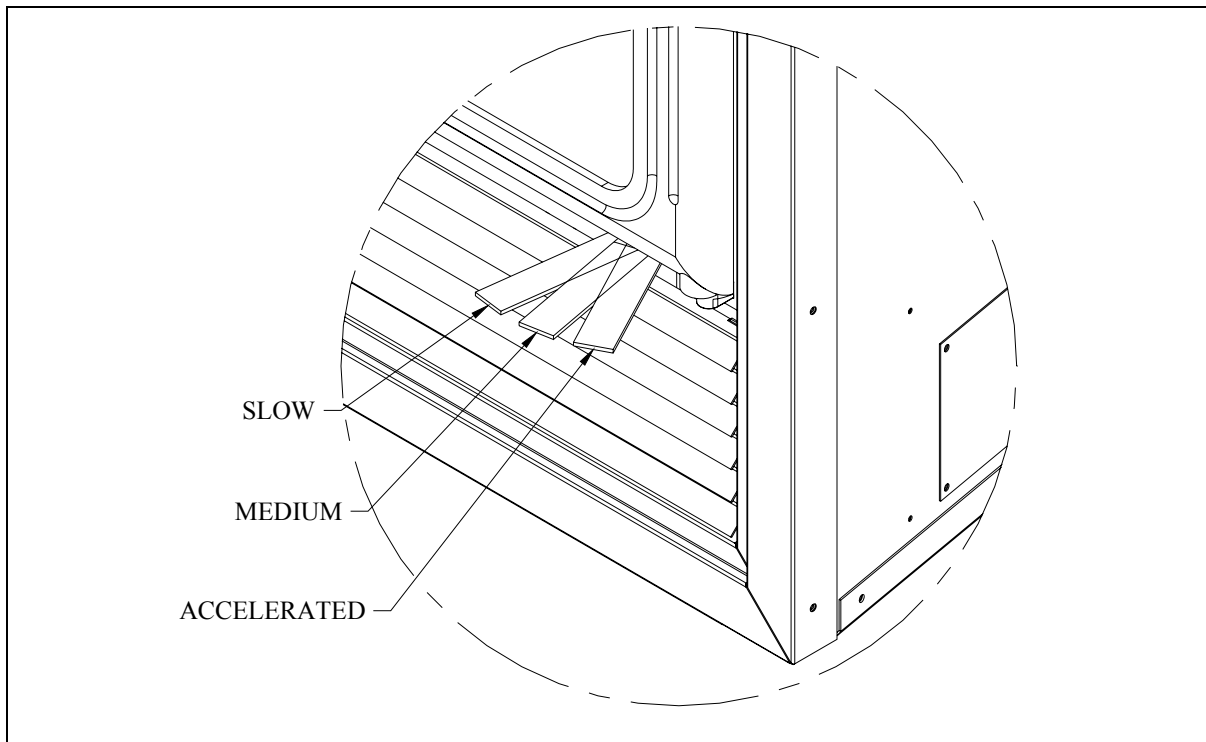

Figure 1

3.2.7 Combustion Settings

Accelerated Combustion

The maximum heat output for the OSBURN *STRATFORD* is achieved by burning with the door closed and the combustion air opened. By this method, the OSBURN *STRATFORD* can produce up to 75,000 BTU of heat per hour. However, it will be necessary to reload with wood every one or two hours. This is the least efficient method of burning the OSBURN *STRATFORD*. Use caution when firing with the combustion air control wide open. Only burn cordwood in this manner. Small dry pieces of softwood and construction scraps will burn very intensely using this method and may damage the firebox.

Medium Combustion

This is the recommended mode of operating the OSBURN *STRATFORD* and should be the one normally used since it will deposit the least amount of creosote on the glass and in the chimney. The combustion air control must be $\frac{3}{4}$ closed. The precise setting will depend on many factors, including chimney length and the moisture content of the wood.

For instance, a long chimney will necessitate closing the combustion air control. To obtain the proper combustion, close the combustion air control completely, then open it about $\frac{1}{4}$ " to $\frac{1}{2}$ ". Three medium size pieces of wood should be burning on a bed of hot coals. The heat output will be approximately 35,000 BTU per hour and the loading time will be about every 3-4 hours. Softwoods may be burned using this method but the time will be substantially reduced.

Slow Combustion

When the air combustion control is completely closed, the fireplace is in a slow combustion phase. If the heart is hot enough, slow combustion will not stop the fire, but there will be a noticeable change in the flame pattern. The flames will be slow and may appear dirty if the wood is too wet (moisture content of 20% and more). Do not allow the wood to burn without flame, since this will produce excessive creosote in the unit.

Creosote may accumulate on the glass door. This method of burning should be used only after operating the OSBURN *STRATFORD* with the air control opened to produce a hot fire for about an hour or at medium pace for at least 2 hours. Slow combustion can be used at night in order to reduce the heat output and to prolong the burn. The refuelling interval time will be between 6-8 hours.

3.2.8 Smoking – Causes and Troubleshooting

To reduce the likelihood of smoking when opening the door, set the combustion air controls to the right (accelerated) before opening the door. Your fireplace has been designed and tested to provide smoke free operation. Occasionally, there may be a small amount of smoking upon lighting the fire, until the chimney heats up but this should not continue. If the fireplace continues to smoke it is probably for one of the following reasons:

A. Negative pressure in the house

As the fire burns, air goes up the chimney. This air must be replaced through leakage into the house or through the fresh air kit. When operating the OSBURN *STRATFORD*, open a nearby window temporarily to check if there is adequate air supply replacement. If opening a window solves the problem, the house is under negative pressure.

B. Fans operating (e.g. : range hood)

These fans draw air out of the house and may actually cause a negative pressure in the house. Turn off all fans and open a nearby window to determine if this is the cause of the problem.

C. Wet wood

Wet or tarred wood will smoulder and smoke instead of burning properly.

D. Dirty or blocked chimney

Check to make sure the chimney is clear and clean.

E. Chimney not long enough

The minimum chimney height is 15 feet (4.6m). not including the fireplace's height. The chimney must extend at least 3 feet (915 mm) above its point of contact with the roof and at least 2 feet (0.6 m) higher than any roof or wall within 10 feet (3 m) of it. When installed with offsets, the minimum chimney height is 15 feet (4.6 m). Additional height will increase draught and will decrease the tendency to smoke.

F. Poor chimney draft

With no fire, there should be sufficient draught to exhaust cigarette smoke introduced under the baffle. Chimneys installed against an outside wall without protection may generate back draught problems which will cause start-up problems. To prevent this, open a nearby window, roll up a piece of paper and light it. Then, hold it in the upper part of the firebox to warm up the chimney. Wait until the draught is sufficient, then start the fire.

IMPORTANT NOTES

- A. Do not block the hot air vents to the fireplace as this will cause the fireplace to overheat.
- B. Never start a fire using gasoline, kerosene, charcoal lighter fluid or any other combustible liquid.
- C. Do not burn coal. The sulphur in coal will corrode the firebox.
- D. Do not burn driftwood which has been in the ocean or salt water. The salt will corrode the firebox and chimney.
- E. Do not abuse the unit by burning paper, or cardboard or construction material such as pressed wood, plywood or lumber.
- F. Do not allow the wood to smoulder or burn without flame, since this will produce excessive creosote in the unit.

3.3 MAINTAINING YOUR OSBURN STRATFORD

3.3.1 Creosote

When wood is burned slowly without a flame, it produces tar and other organic vapours which combine with expelled moisture to form a black deposit called creosote. Creosote accumulates on the flue lining. When ignited, this creosote makes an extremely hot fire. If the creosote accumulation is large, a creosote fire in the chimney can damage the chimney and overheat the surrounding wood framing. Creosote formation in a chimney can be minimized by making sure there is always visible flame burning, avoid smouldering fires and by proper refueling techniques.

3.2.2 Chimney Maintenance

Regular chimney inspection and maintenance combined with proper operation will prevent chimney fires. Keep your chimney clean. Do not allow more than 1/16" creosote build up in your chimney. The amount of creosote will depend on variables such as frequency of use and type of fire. We recommend that you:

- A. Initially inspect the chimney system weekly. From this, you will learn how often it will be necessary to clean your chimney.
- B. Have your chimney cleaned by a qualified chimney sweep. If you wish to clean it yourself, we recommend using a stiff plastic or non-metallic brush. If a metal brush is used, its size should be slightly smaller than the flue to avoid damaging the chimney. Do not use a brush that will scratch the stainless steel interior of the chimney.
- C. Do not expect chemical cleaners to keep your chimney clean. The rain cap can be removed for inspection and/or cleaning of the chimney.

3.3.3 Top Baffle Removal Prior to Cleaning the Chimney

Before starting to clean your chimney, we recommend that you remove the top baffle to avoid creosote dust collection at the top of the baffle. Follow these steps to set the top baffle out of the way:

1. Remove the front air tube by pulling out the cutter pin on the side of the tube. They are located at the top, underneath the baffle.
2. Lift the baffle and slide it out of the fireplace. You now have access to the chimney.

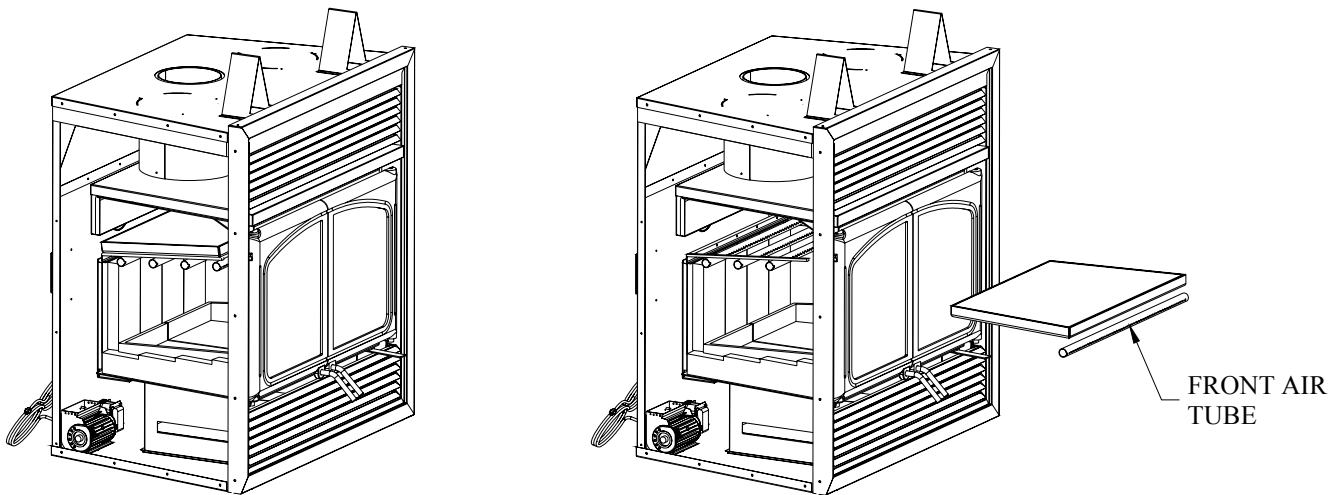

Figure 2

3.3.4 Dealing with a Chimney Fire

Regular chimney maintenance and inspection can prevent chimney fires. If you have a chimney fire, follow these steps:

1. Close the fireplace door and the combustion air controls;
2. Alert your family of the possible danger;
3. If you require assistance, alert your fire department;
4. If possible, use a dry chemical fire extinguisher, baking soda or sand to control the fire. Do not use water as it may cause a dangerous steam explosion;
5. Check outside to ensure that sparks and hot embers coming out of the chimney are not igniting the roof;
6. Do not use the fireplace again until your chimney and fireplace have been inspected by a qualified chimney sweep or a Fire Department Inspector;

3.3.5 Plated Finish Maintenance

Use a glass cleaner and a soft cloth to polish the plated finish on the door frame. Do not use abrasives such as steel wool, steel pads or an abrasive polish for they may scratch the finish.

3.3.6 Ashes

Remove ashes only when the fire is out and the ashes are cold (24 to 48 hours after the fire is out).

3.3.7 Refractory Replacement

The intense heat of the fire will normally cause hairline cracks in the refractory. These cracks can be minimized by proper curing as described in “First Fires”. They will not normally diminish the effectiveness of the refractory. If large cracks develop, then the refractory should be replaced. To replace the refractory bricks, follow these steps:

1. Remove the left side bricks
2. Remove the right side bricks
3. Remove the back bricks
4. Remove the two floor bricks

To install the new bricks, follow the above steps in reverse.

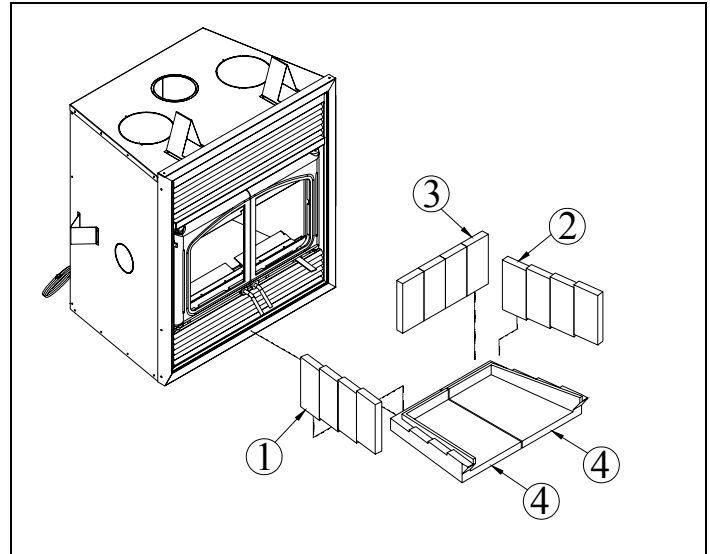

Figure 3

3.3.8 Glass Care – Replacement

The glass used for the OSBRUN *STRATFORD* is a high temperature ceramic glass (1400° F). If the glass breaks, it must be replaced with an identical ceramic glass. Tempered glass or ordinary glass will not withstand the high temperatures of the OSBRUN *STRATFORD*. Replacement glass should be purchased from a Osburn dealer (see “Replacement Parts”, in Section 7 – APPENDIX). Do not operate the unit with a cracked or broken glass.

3.3.9 Glass Care – Cleaning

The OSBRUN *STRATFORD* is designed to keep the glass clean under normal operating conditions. If the OSBRUN *STRATFORD* is operated continuously with the combustion air controls closed, the glass will tend to get dirty unless the fuel, firebox and glass are maintained at hot. To clean the glass, there are a number of specially designed cleaners. Your authorized Osburn dealer can recommend a suitable cleaner which is available in your area. Regular household glass cleaners will not clean creosote. Do not use abrasives such as steel pads, steel wool or oven cleaner as they will scratch the glass.

3.3.10 Gasket Replacement

Remove the doors from the unit and lay them on a clean, unabrasive surface. To replace the gasket around the door frame, first remove the old gasket and adhesive. Make sure that the surface is totally clean before applying new adhesive (a high temperature silicone caulking

rated for at least 500°F, 260°C, is suitable) or adhesion problems may result. Apply the adhesive inside the door groove (gasket channel) and install the new gasket with a gentle pressure. Let dry for at least 24 hours. To replace the glass gasket, simply remove the glass retainers holding the glass to the door frame. Remove the glass and peel off the gasket surrounding it. Replace it by a new, self-adhesive glass gasket. The proper replacement gaskets are available from your Osburn dealer in the following dimensions:

<u>Gasket</u>	<u>Length</u>	<u>Dimensions</u>
Around each glass	51 ½" (131 cm)	U SHAPE
On each door frame	41 ¼" (105 cm)	Flat ¼" x ½"
Along the door joint	14" (36 cm)	Flat ¼" x ½"

3.4 FIREPLACE INSTALLATION

3.4.1 Locating the OSBURN STRATFORD

- A. The best location to install your fireplace is determined by considering the location of windows, doors, and the traffic flow in the room where the fireplace is located, allowing space in front of the unit for the heart extension and the mantel, and taking into consideration the location of the hot air ducts (optional), outside air kit and chimney. If possible, you should choose a location where the chimney will pass through the house without cutting floor or roof joists.
- B. Usually, no additional floor support is needed for the fireplace. The adequacy of the floor can be checked by first estimating the weight of the fireplace system. Weights are given in the appendix. Next, measure the area occupied by the fireplace which is normally 36" × 26". Note the floor construction and consult your local building code to determine if additional support is needed.
- C. The OSBURN *STRATFORD* may be installed directly on the floor or on a raised base (for proper guidelines, refer to "Heart Extension Requirements") and a minimum of 7 feet (2.15 m) measured from the base of the appliance to the ceiling is required.

3.4.2 Heart Extension Requirements

The OSBURN *STRATFORD* may be installed directly on a combustible floor; however, the combustible floor in front of the fireplace must be covered with a non-combustible material (tile, marble, stone, etc.). The hearth extension floor area shall extend at least 16" in front and at least 8" on each side of the fireplace opening. (see figure 4). If the fireplace is to be used with a fireguard, the floor protector in front of the fireplace must have a R value of 1.53 or greater.

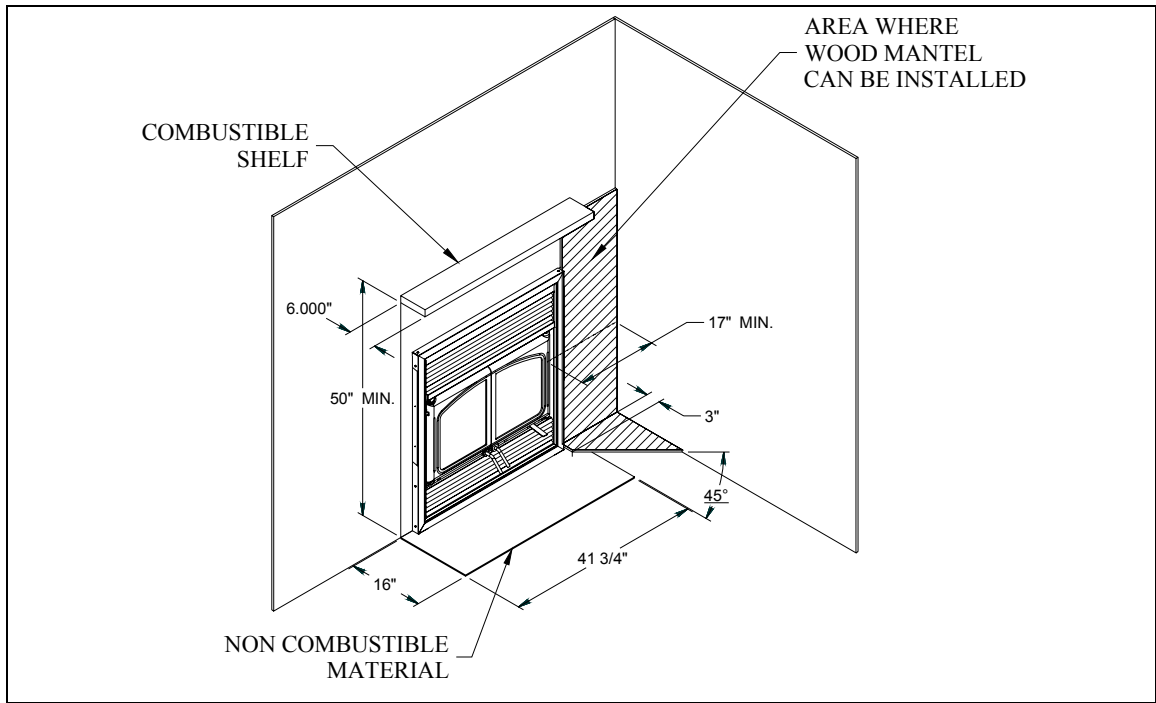

Figure 4

3.4.3 Framing, Facing, Mantel, and Combustible Shelf

The construction of the framing, facing, and mantel must be in accordance with the standards and the following illustrations (figures 4 to 11):

- A. Frame the fireplace using 2" × 3" or heavier lumber.
- B. **WARNING:** Combustible framing material cannot be used in the space directly above the fireplace, except for the studs above the facing that support the facing material and mantel. This area must remain empty for **a height of 7' (2,15 m)** measured from the base of the appliance.
- C. Frame the fireplace with vertical studs at the sides of the fireplace running from floor to ceiling (see figure 6). Position the studs back from the front edge of the fireplace, a space the thickness of the facing material so that the facing can be installed flush with the fireplace facing (within limitations of figure 11). Frame headers between the vertical studs only as follows:
 - Place 2" × 3" or 2" × 4" headers, only along the upper part of the front, side and back faces. Do not put wood or any combustible material within the area above the fireplace except on the front facing.
 - Place headers only as required to support the facing and mantel.
- D. **WARNING:** The fireplace must not be in contact with any insulation or loose filling material. Cover the insulation with gyproc panels around the fireplace.

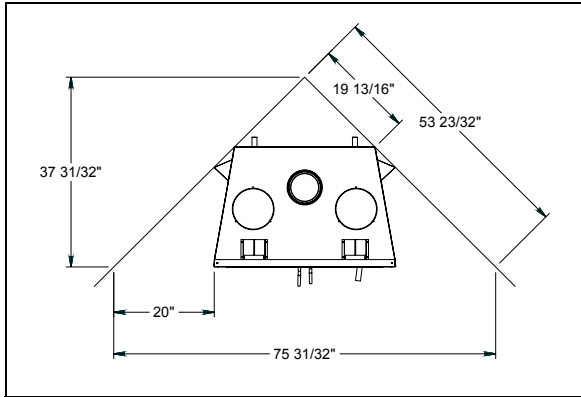

Figure 5

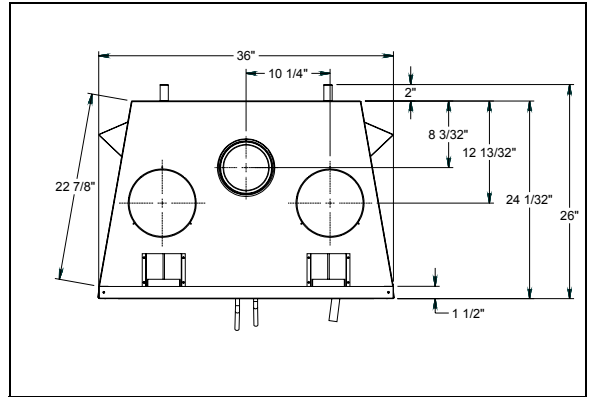

Figure 7

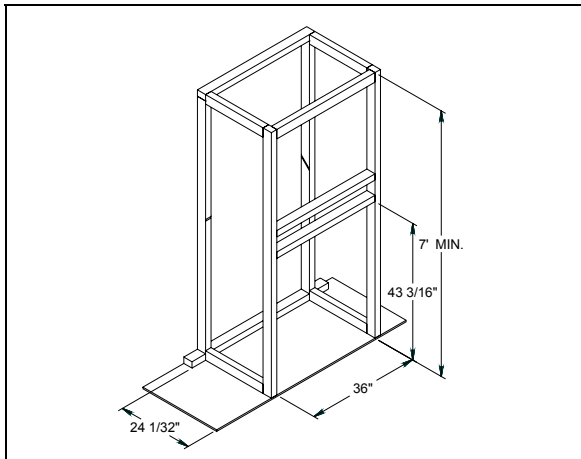

Figure 6

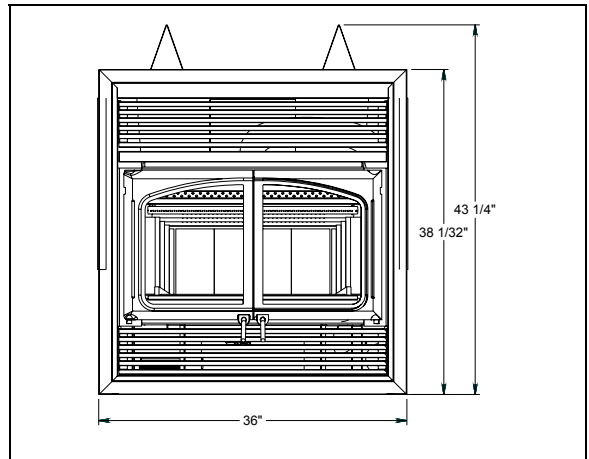

Figure 8

INSULATED CHASE CONSTRUCTION

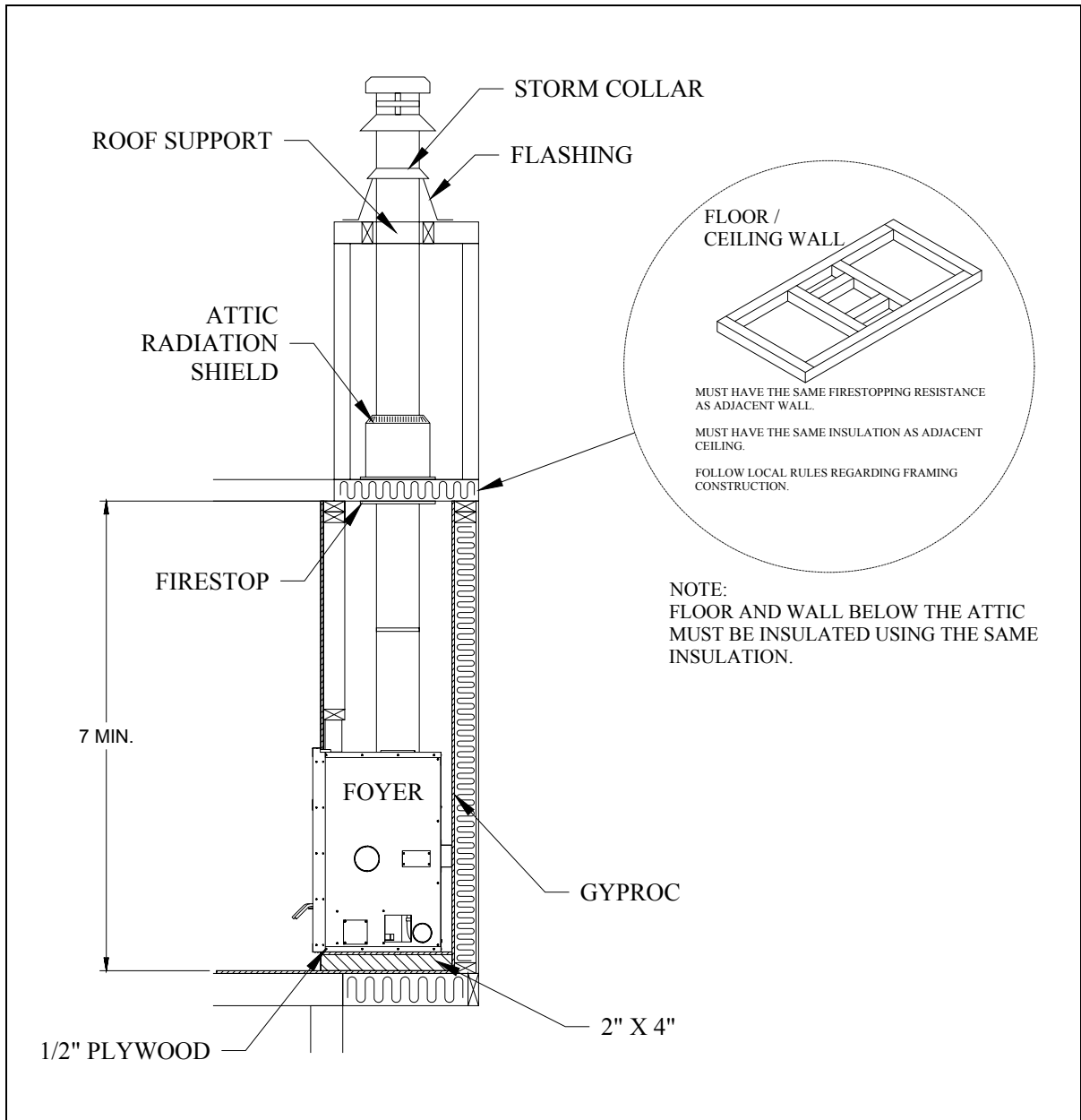

Figure 9

Facing

1. Combustible material may be installed flush with the fireplace decorative frame. Combustible material may not project in front of and onto the fireplace decorative frame (figure 11).
2. Non-combustible materials such as brick, stone or ceramic tile may project in front of and onto the fireplace decorative frame.

Combustible shelf

Any combustible shelf must be installed at least 50" (127 cm) above the base of the fireplace if the depth of the shelf is 6" or less. If the depth of the shelf is more than 6" but less than 12", the shelf must be installed at least 52" (132 cm) from the base of the fireplace (see figure 10).

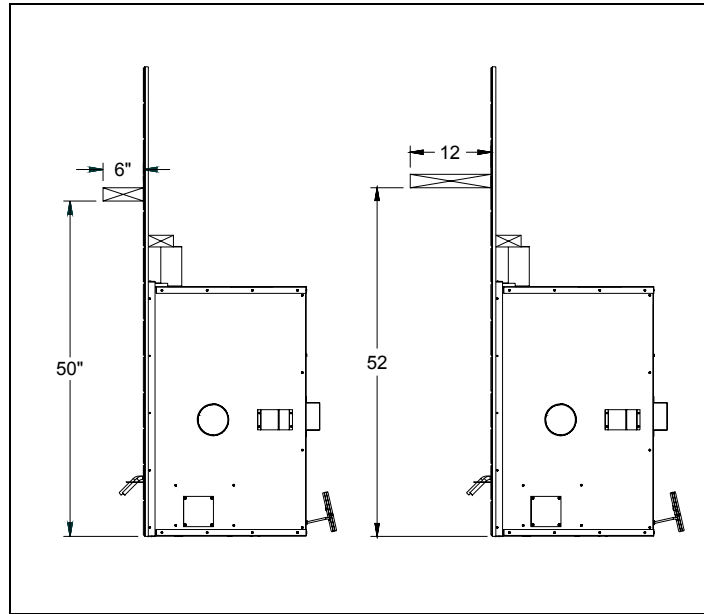

Figure 10

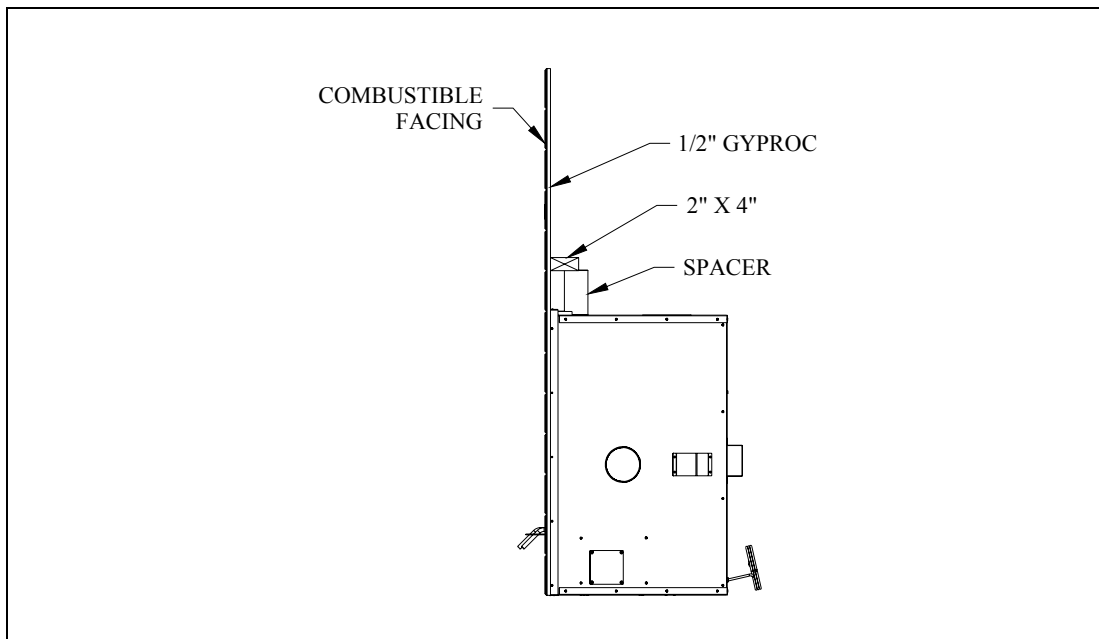

Figure 11

3.5 HOT AIR DUCTING INSTALLATION

Different hot air ducting systems can be installed with the OSBURN *STRATFORD*:

- Gravity kit
- Forced air kit

3.5.1 Gravity Kit

The kit includes:

- 2 x hot air outlets (grilles and frames);
- 2 x 90° elbows with brackets;
- 1 deflector.

The gravity kit allows you to block the upper fireplace louver. To do so, follow the steps below:

- Remove the upper louver from the fireplace;
- Install the deflector as shown on figure 12;
- Put the upper louver back into place.

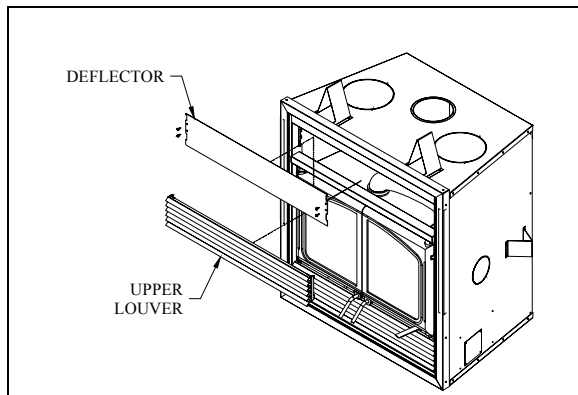

Figure 12

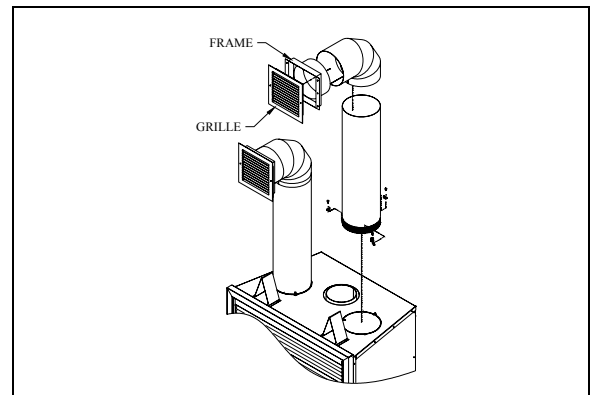

Figure 13

The safety rules for hot air ducting gravity kit installations are the following:

Minimum height*	68" (1.7 m)
Maximum length	10' (3m) (see figure 14)

*The minimum height of the hot air ducting must be measured from the floor to the top of the hot air grilles.

The hot air grilles can be installed in the same room as the fireplace, or one or both of the grilles can be installed in adjacent or upper rooms. Installing the ducts at different elevations will tend to exhaust more heat out of the higher grilles (figure 15).

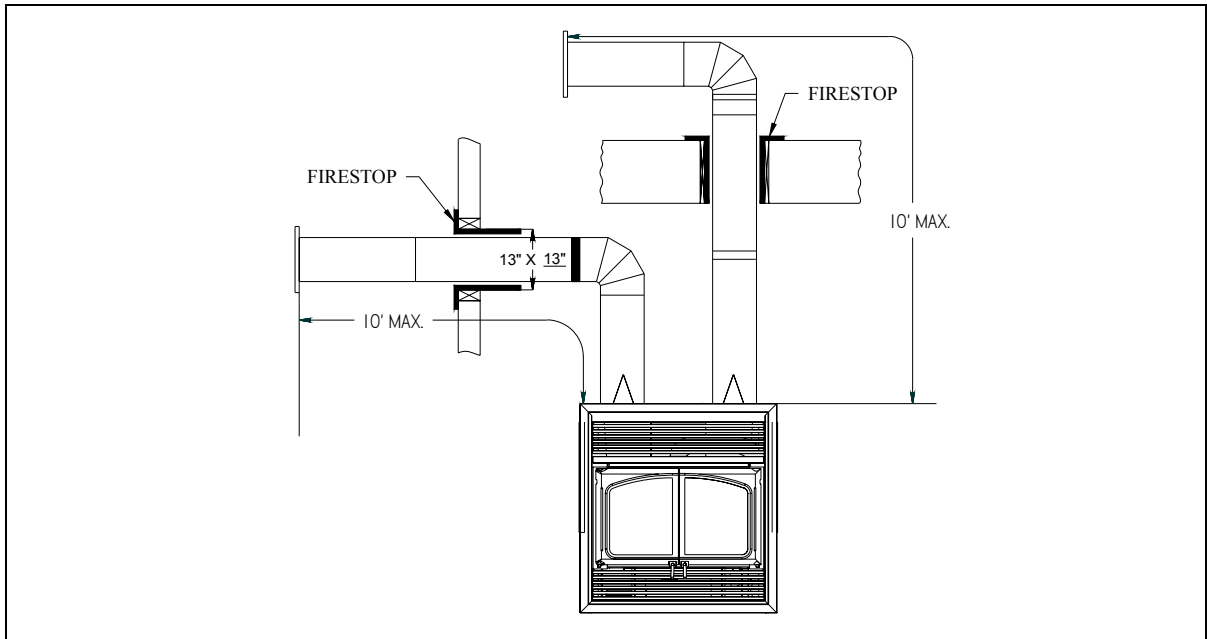

Figure 14

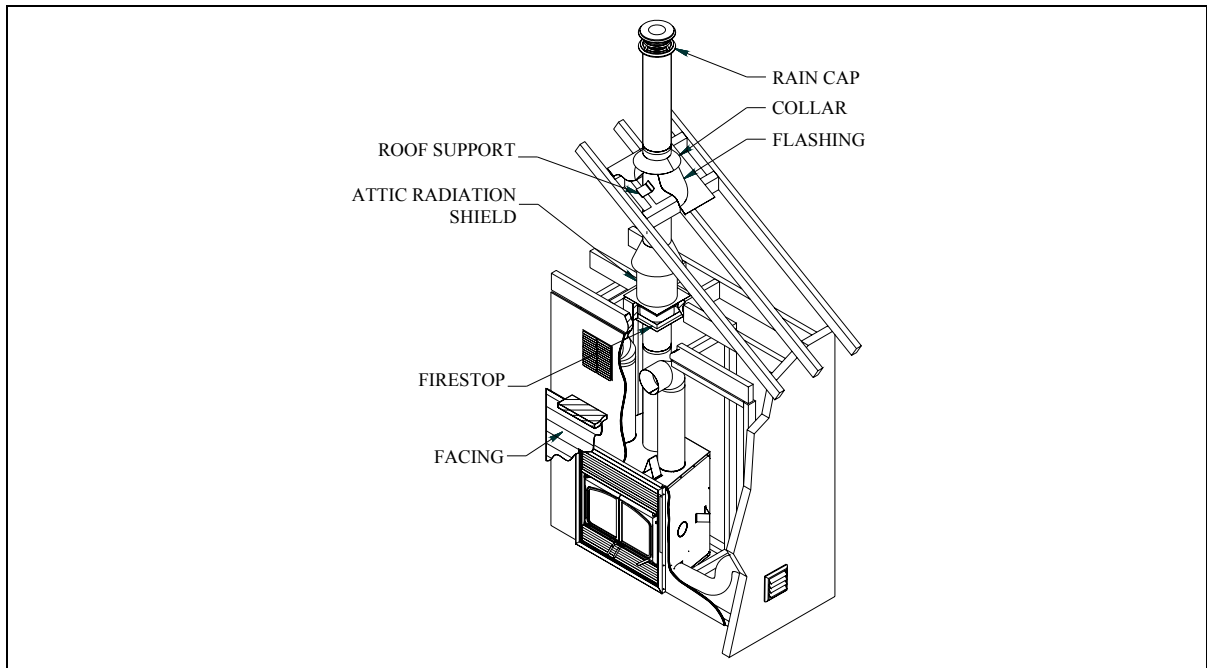

Figure 15

The duct system must be installed respecting the following:

1. Remove the plates closing up the 8" dia. holes on top of the fireplace. Then, cut the insulation in order to obtain two 8" dia. openings. Insert the ducting into each opening and fix it in place using the 6 steel brackets supplied (3 for each duct).
2. Maintain at least a 2" (50 mm) clearance between the ducts and the firestop; the required hole size for the hot air grilles (outlet) is 8¼" × 8¼" (210 mm × 210 mm).

3. The maximum number of elbows in a run of duct is two.
4. Maintain at least 10" (254 mm) clearance from the outlet grille framing to a combustible ceiling, side wall or mantel.
5. When passing through a combustible wall or floor, a firestop must be installed at the wall or floor penetration. The hole size must be in accordance with the duct manufacturer's instructions.
6. Do not connect the hot air ducts to a central heating system. Malfunction of the heating system's fan will cause the fireplace to overheat.
8. Do not use insulated flexible ducts as they may overheat.
9. Do not use tees or any other components than the ones specifically listed here.
10. All ducts must extend upwards or horizontally. **Never route the ducting downwards.**
11. The hot air outlet grilles must be installed with the louvers pointing downwards in order to prevent overheating adjacent ceilings.
12. Always install the two outlet grilles when using the hot air outlet kit and blocking the upper louver of the fireplace.

3.5.2 Central Forced Air Kit (Not tested under EPA certification)

The knock-outs provided on the back and on the sides of the OSBURN *STRATFORD* allow the connection of insulated flexible pipe which enables you to heat adjacent rooms up to 50 feet from the fireplace (see figure 18).

The ducting system must be installed as described below:

- A) Remove the knock outs at the back and/or the side of the fireplace and cut the insulation around the hole. Fix the adapter into place with screws. You can use more than one outlet on the fireplace (figure 16);
- B) Attach the 5" flexible pipe, using the collars provided. Important: Make sure that the plastic wrapping around the flexible pipe is not in contact with the fireplace;
- C) Attach the flexible pipe to the fan's air inlet using the collars provided (figure 17);
- D) Attach a flexible pipe to the fan's air outlet and route the flexible pipe to the chosen location. The ducting system can be installed either in an upper room or in a lower room;
- E) At that point, the flexible pipe can be attached to any air distribution grille.
- F) Make the electrical connections to the PC Board as explained with the forced air kit owner's manual.

Since the forced air kit requires electricity, make sure that the connections to the fan have been made according to the local codes and comply with their requirements (see instruction provided with the kit).

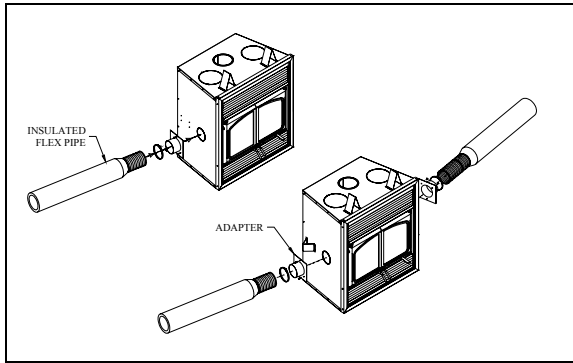

Figure 16

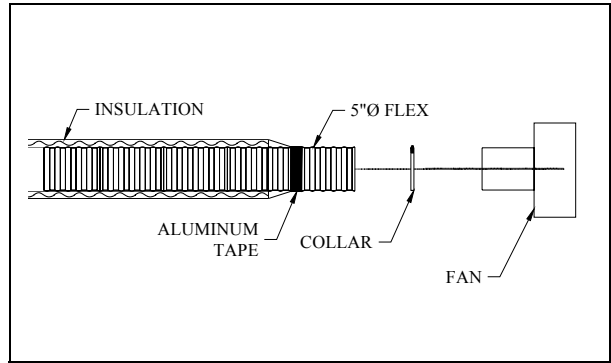

Figure 17

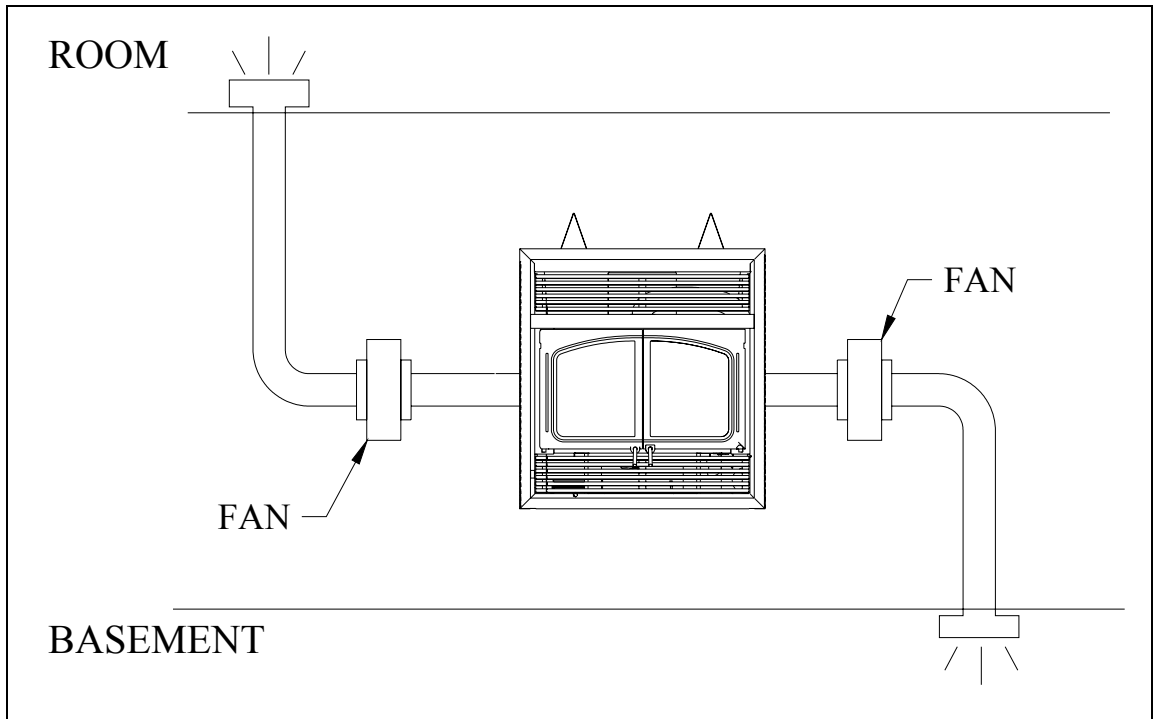

Figure 18

3.6 **FRESH AIR KIT (Optional)**

During operation, the fireplace requires fresh air for combustion and draws air out of the house. It may starve other fuel burning appliances such as gas or oil furnaces. As well, exhaust fans may compete for air, causing negative pressure in the house, resulting in smoke entering the house from the fireplace. This situation is aggravated in modern airtight houses. To overcome this problem, we strongly recommend that you **install fresh air kit. Check with local authorities having jurisdiction in your area, it may be mandatory.**

3.6.1 **Outside Air Installation**

The fresh air kit may be installed according to the following requirements:

- A) Duct length should be kept to a minimum. The maximum length of a 3" I.D. (76 mm) insulated flexible duct is 30 ft. (9 m).
- B) The air intake register must not be installed more than 10 ft. (3 m) above the base of the fireplace.
- C) The fresh air must come from outside the house. The air intake must not draw air from the attic, from the basement, or from a garage.
- D) The air intake should be installed where it is not likely to be blocked by snow or exposed to extreme wind and away from automobile exhaust fumes, gas meter and other vents.
- E) The duct and register may be installed above or below floor level.

The fresh air kit for your OSBURN *STRATFORD* contains the following components:

- 1- A 3" flex adapter;
- 2- 2 pipe clamps;
- 3- An outside air register.

To complete the fresh air kit installation, you will need a 3" insulated flexible pipe. Use the length required for your installation while respecting the maximum length of 30 ft (9 m).

Make a 3 ¼" (83 mm) hole in the outside wall of the house at the chosen location. From outside, place the outside air register in the hole (open side down) and fasten the register to the wall, with screws as shown (see figure 19). Place the insulated pipe over the register tube and over the fireplace's outside air connector (see figure 20). At each end, carefully pull back the insulation and plastic cover, exposing the flexible pipe. Attach the flexible pipe using pipe clamps. For a better seal, you may also use aluminum tape. Wrap the tape around the joint between the flexible pipe and the air inlets. Carefully push the insulation and plastic cover back over the pipe. Fix the plastic in place using aluminum tape.

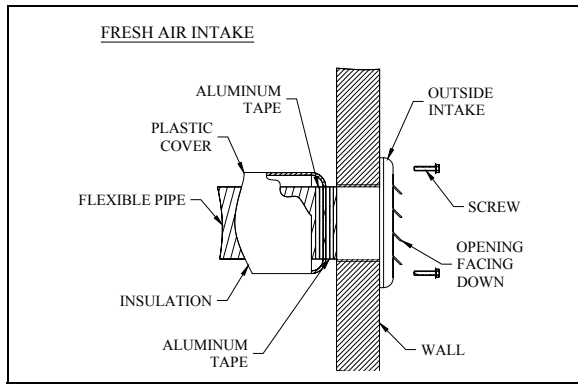

Figure 19

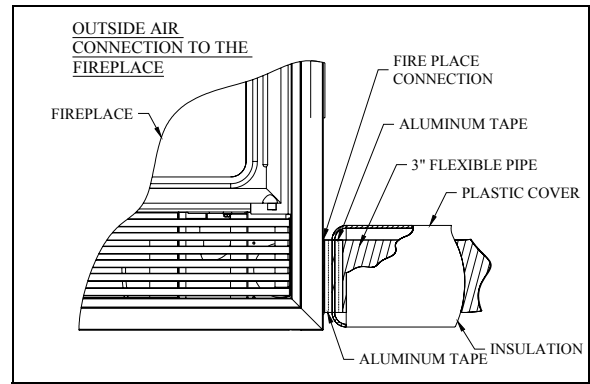

Figure 20

3.7 DOOR OVERLAY INSTALLATION

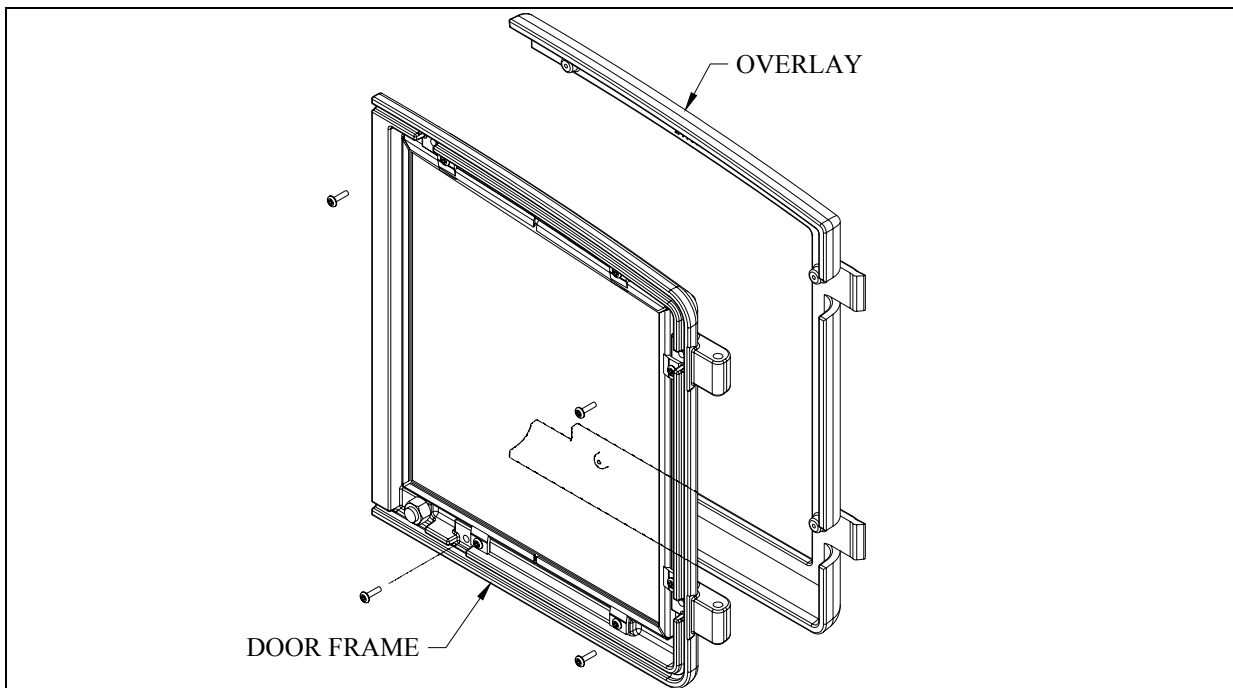

Figure 21

In order to install the door overlay, simply place the overlay over the door frame. From behind the door frame, locate the 4 attachment holes and use the 4 screws provided with the overlay to secure it to the door frame.

4. THE CHIMNEY

4.1 CHIMNEY INSTALLATION NOTES

1. If possible, install an interior chimney as it will provide better performance. In areas with continuous temperatures below -18°C (0°F), the use of an exterior chimney increases the likelihood of operating problems such as low draught, high rate of creosoting, and poor start-up characteristics. Exterior chimneys are also prone to down-drafting and flow reversal. Installations, which are located on lower floors in the house, such as in a basement, in combination with outside chimney, are especially prone to flow reversal.
2. The OSBURN *STRATFORD* is listed only with chimney systems described in table 2.
3. A chimney venting a fireplace shall not vent any other appliance.
4. The minimum chimney height is 15 ft. (4.6 m).
5. All chimney installations must include at least one support. Reducing the amount of chimney weight on the fireplace will help avoid the noise created when the fireplace expands. This can be achieved by having the chimney supported by the supports. The maximum chimney length that should be supported by the fireplace is 9 ft. (2.75 m) for 2" Solid Pack Chimney, 12 ft. (3.7 m) for 1" Solid Pack Chimney, and 26 ft. (8 m) for AC Triple Wall Chimney.
6. The chimney must extend at least 3 ft. (1 m) above its point of contact with the roof and at least 2 ft. (0.6 m) higher than any wall, roof or building within 10 ft. (3 m) of it (Figure 21).
7. If the chimney extends higher than 5 ft. (1.5 m) above its point of contact with the roof, it must be secured using a roof brace.
8. A rain cap must be installed on top of the chimney. Failure to install a rain cap may cause corrosion problems.
9. Cut and frame square holes in all floors, ceilings, and roof that the chimney will go through to provide a 2" (50 mm) clearance between the chimney and any combustible materials. Do not fill this 2" space with insulation or any other combustible material.
10. Portions of the chimney which may extend through accessible spaces must be enclosed to avoid contact with combustible materials or damage the chimney.

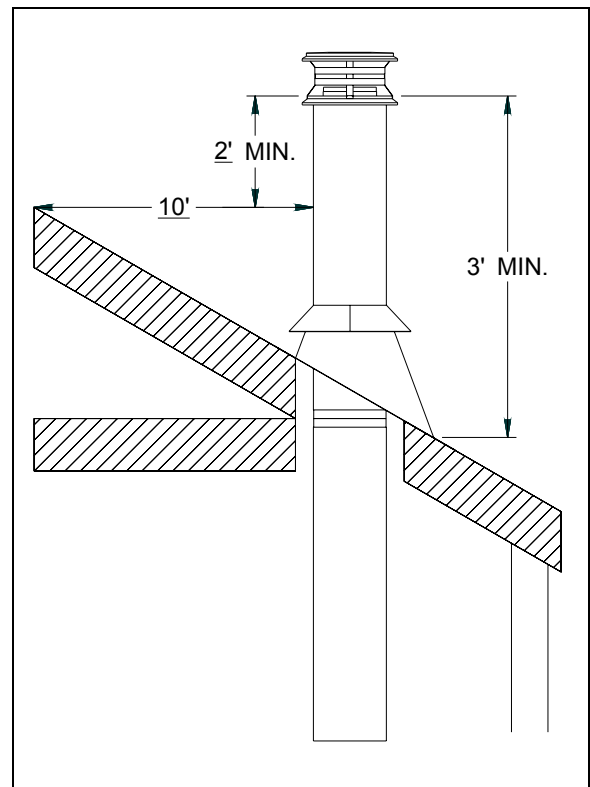

Figure 22

4.2 CHIMNEY INSTALLATION INSTRUCTIONS

1. Cut and frame the holes in the ceiling, floor and roof where the chimney will pass (see figure 23). Use a plumb bob to line up the center of the holes. Make sure that the size of the floor and ceiling holes are in accordance with the chimney manufacturer's instructions.

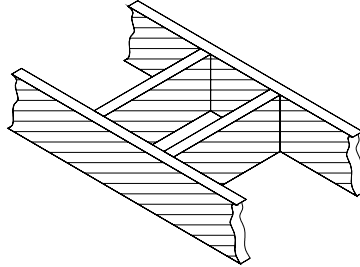

Figure 23

2. From below, install a firestop supplied by the chimney manufacturer in each ceiling/floor separation through which the chimney will pass. At the attic level, install an attic radiation shield from above (see figure 24).
3. Follow the chimney's manufacturers' instructions and place the first chimney length on the fireplace. For all chimneys, you must use an anchor plate supplied by the chimney manufacturer before installing the first chimney length (see figure 24). Continue installing chimney lengths making sure to lock each length in place.
4. Every time the chimney passes through a ceiling or a wall, install the appropriate firestop. When you reach the desired height, install the roof support. (Refer to instructions included with the support.)
5. Then, put the roof flashing in place and seal the joint between the roof and the flashing with roofing pitch (see figures 24). For sloping roofs, place the flashing under the upper shingles and on top of the lower shingles. Nail the flashing to the roof, using roofing nails.
6. Place the storm collar over the flashing, and tighten it with the bolt supplied. Finally, seal the joint between the storm collar and the chimney, using silicone caulking.
7. Install the chimney cap.
8. When a ventilated roof flashing is installed, precautions are to be taken not to caulk or seal the ventilating openings.

EXAMPLE OF TYPICAL CHIMNEY INSTALLATION

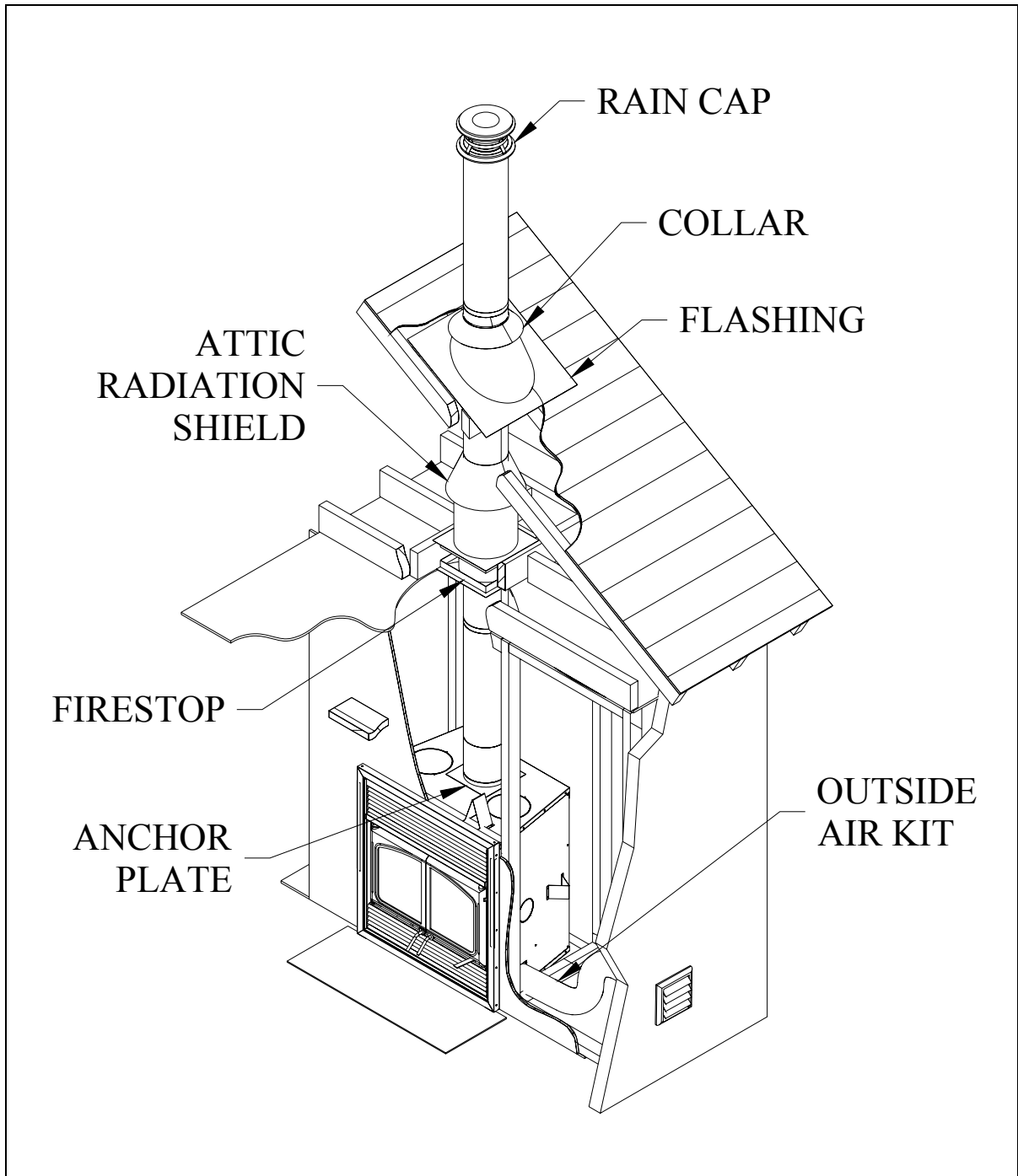

Figure 24

4.3 **OFFSET CHIMNEY INSTALLATION**

The minimum chimney height when using elbows is:

Fireplace model	OSBURN <i>STRATFORD</i>
Chimney model	All models
Vertical installation	15 ft. (4.6 m)
Two (2) elbows	15 ft. (4.6 m)
Four (4) elbows	17 ft. (5.2 m)

Table 1

After reaching the location requiring the elbow, proceed as follows:

1. Install the first elbow; turn it in the required direction. Secure it to the chimney according to the chimney manufacturer's instructions. In many cases, it is recommended to secure connections with three (3) ½" (12 mm) metal screws.
2. Install the necessary chimney lengths to achieve the required offset. Lock the chimney lengths together according to the chimney manufacturer's instructions. In many cases, it is recommended to use three (3) ½" (12 mm) screws. If the offset length is made of two (2) chimney lengths or more, many chimney manufacturers may require that you use an offset or roof support halfway up the offset. If penetrating a wall, install a wall radiation shield supplied by the chimney manufacturer (see figures 25 & 26).
3. Use another elbow to turn the chimney vertically. Secure the elbow.
4. Use a plumb bob to line up the centre of the hole. Cut a hole for the chimney in the ceiling/floor. Frame this hole as described previously.
5. From below, install a firestop supplied by the chimney manufacturer (see figure 24).
6. A support must be used on the first 15' section (4.6 m).
7. Continue with the regular installation.

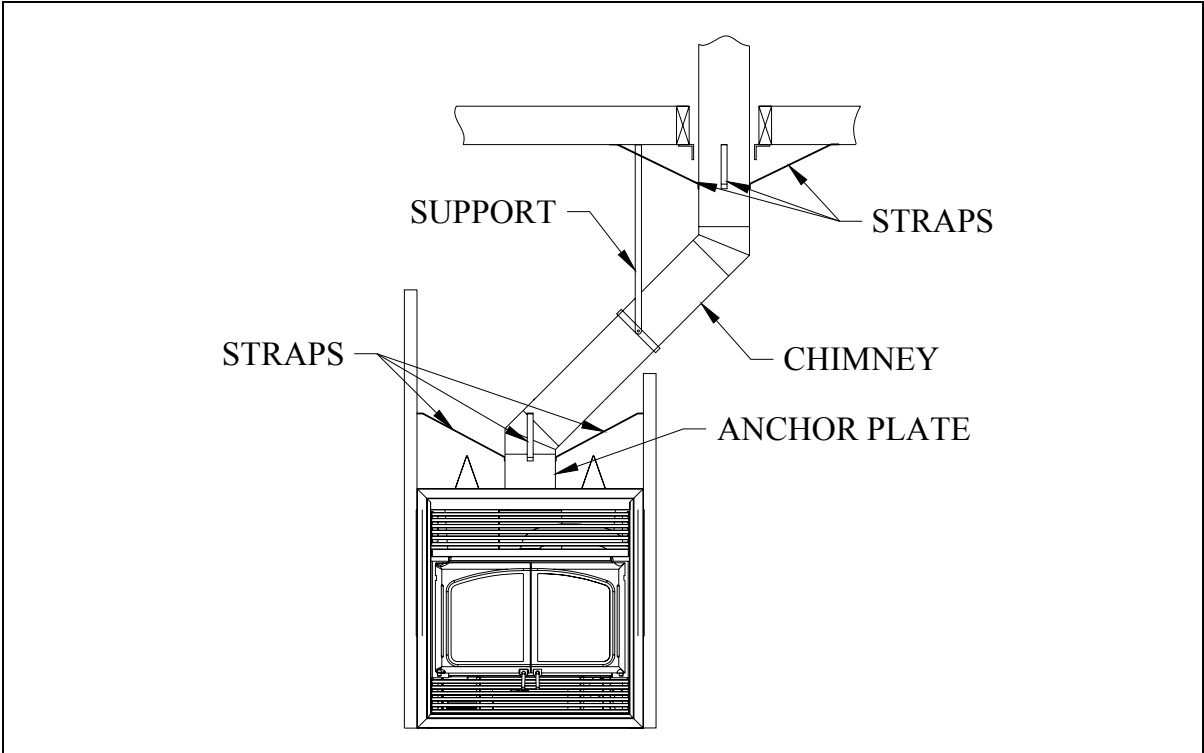

Figure 25

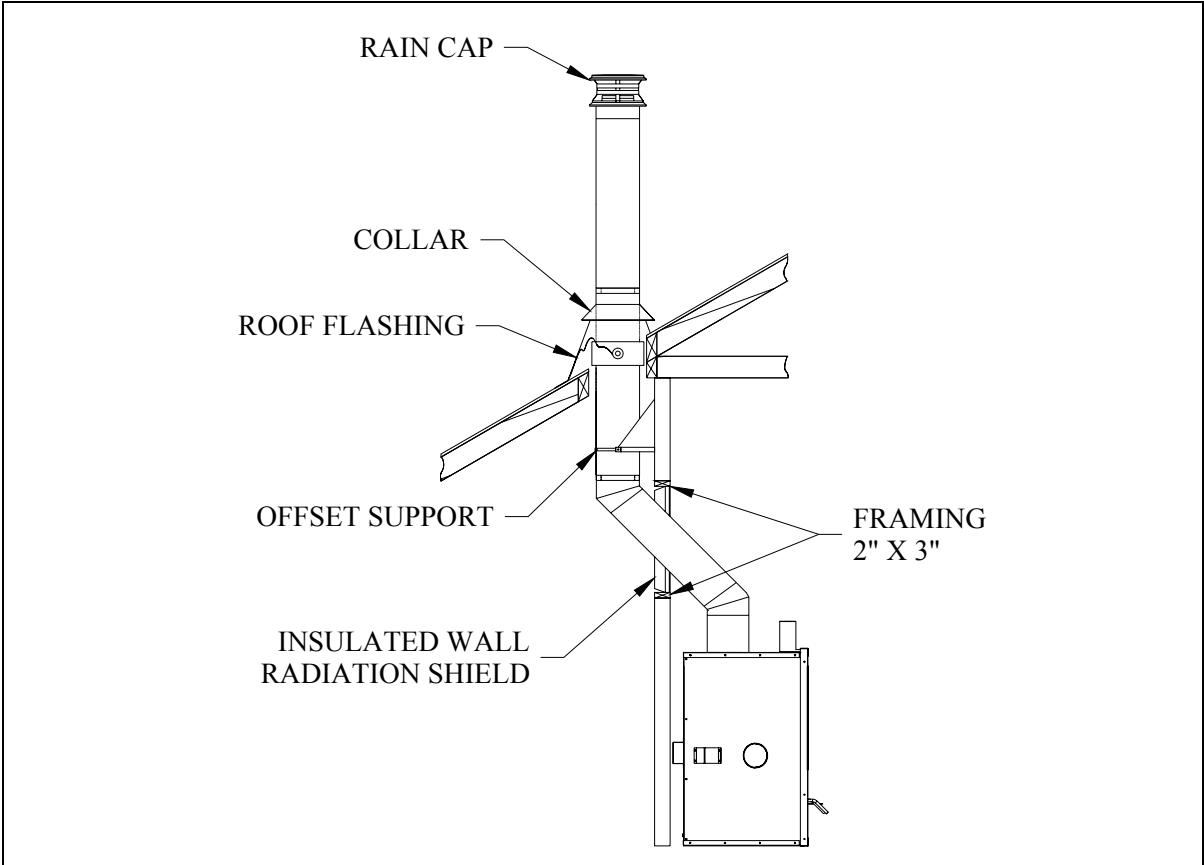

Figure 26

TABLE 2 - LISTED CHIMNEYS FOR YOUR OSBURN STRATFORD

CHIMNEY MANUFACTURER	BRAND	TYPE	INNER DIAMETER
Selkirk	Ultra-Temp	1" Solid Pack	6"
Selkirk	Super Pro	1" Solid Pack	6"
Selkirk	Super Vent	1" Solid Pack	6"
Selkirk	CF Sentinel	2" Solid Pack	6"
Selkirk	Super Pro 2100	2" Solid Pack	6"
Selkirk	Super Vent 2100	2" Solid Pack	6"
Security Chimney	ASHT+	1" Solid Pack	6"
Security Chimney	S-2100	2" Solid Pack	6"
Simpson Dura-Vent	Dura Tech	1" Solid Pack	6"
Simpson Dura-Vent	Dura Plus	AC Triple Wall	6"
American Metal	Model HSS	AC Triple Wall	6"
American Metal	Model HS	AC Triple Wall	6"
ICC	Excel 2100	1" Solid Pack	6"

TABLE 3 – LIST OF MANDATORY COMPONENTS

CHIMNEY MANUFACTURER	MANDATORY COMPONENTS	TYPE/BRAND
Selkirk	<ul style="list-style-type: none"> Ventilated roof flashing. Must have joist protector at the roof level if the fireplace is to be used with a fireguard (see section 5) 	Ultra-Temp, Super Pro, Super vent.
Security Chimney	<ul style="list-style-type: none"> Joist protector at the roof level (see section 5) Requires insulated attic radiation shield unless chimney is enclosed at the attic level. 	ASHT +
Simpson Dura-Vent	<ul style="list-style-type: none"> Ventilated roof flashing with joist protector at the roof level (see section 5) 	Dura Tech
ICC	<ul style="list-style-type: none"> Ventilated roof flashing 	Excel 2100

NOTE: If the fireplace is to be used with a fireguard, the floor protector in front of the fireplace must have a R value of 1.53 or greater.

4.4 ANGLED WALL RADIATION SHIELD

When passing through a combustible wall with the chimney at a 30° or 45° angle (30° or 45° in Canada and 30° only in the USA), an angled firestop or wall radiation shield provided by the chimney manufacturer must be installed. Only one is required. Follow the chimney manufacturer's installation instructions.

In cold climate locations, it is recommended that you use the insulated wall radiation shield since it will maintain the home's thermal barrier.

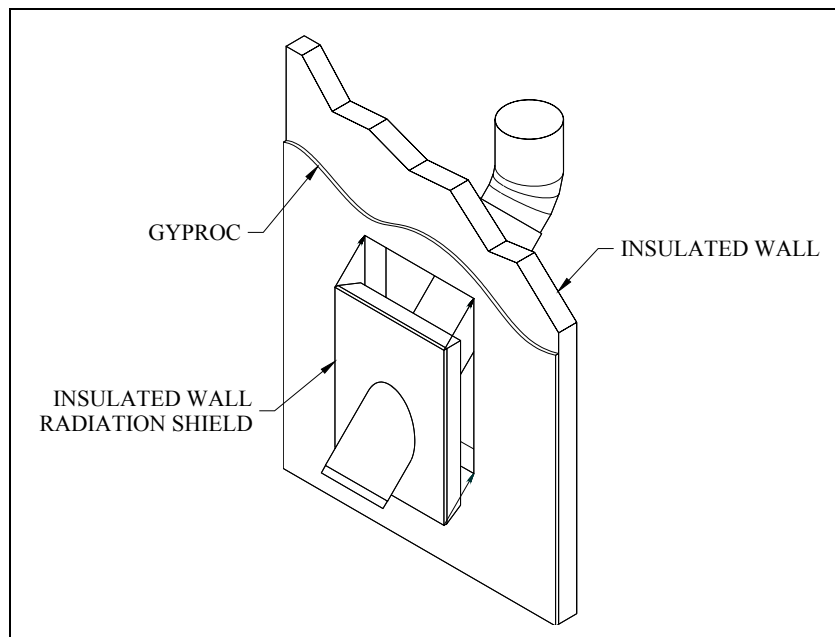

Figure 27

4.5 CHIMNEY SUPPORT INSTALLATION

Universal Roof Support

This support has three possible uses:

1. It must be used on a roof to support the chimney.
2. It may be used on a floor, ceiling or roof above an offset to support the chimney above the offset.
3. It may be used on a floor, ceiling or roof as a supplementary support.

For roof support installation, refer to the instructions provided with the support by the chimney manufacturer. Many manufacturers will provide the maximum height of chimney that can be supported by the support. Make sure you respect those parameters.

Universal Offset Support

This support is used to support the chimney above an offset. When the chimney offset is used to pass through a wall, this support may be used on the wall to support the chimney. For offset support installation, refer to the instructions provided with the support by the chimney manufacturer. Many manufacturers will provide the maximum height of chimney that can be supported by the support. Make sure you respect those parameters.

4.6 CHIMNEY CHASE AND MULTIPLE TERMINATIONS

For the purpose of this manual, a chimney chase is considered a part of the chimney system rather than part of a building. The termination must be placed a minimum of 18" (460 mm) above the chase.

For installations where more than one chimney is located in the same chase or within the same area, we suggest that their terminations be separated by at least 16" (410 mm) horizontally, and 18" (460 mm) vertically. This separation is to prevent smoke migrating from one chimney to another (see figure 28).

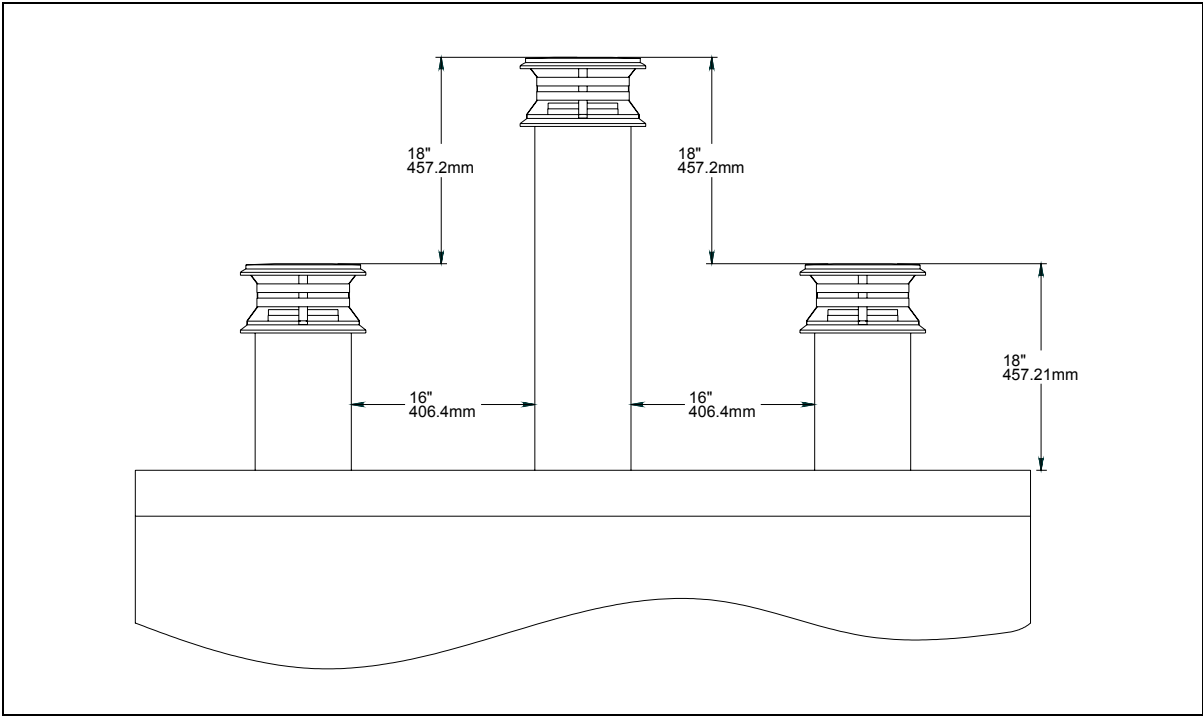

Figure 28

4.7 INSTALLATION INSTRUCTIONS FOR MASONRY APPLICATION

WARNING: Before starting the installation, the masonry chimney must be inspected by a qualified sweep.

The following requirements must be respected:

1. The chimney must be absolutely clear of any soot residue or creosote. Check for cracks, loose or missing bricks that could inhibit correct installation of the liner.
2. The clearance to combustibles must be a minimum of 1" between the outside of the masonry and any wood framing or loose insulation.
3. The chimney must be built in accordance with the current building code.
4. No other appliance can be connected to the same chimney.

Installation:

The chimney must be relined with a stainless steel liner of the same diameter as the outlet of the fireplace. For connection at 30° or 45° angle, a special connector must be used to connect the liner to the insulated chimney. Verify availability and installation instructions for this connector with the chimney manufacturer.

Follow these steps:

1. Position the fireplace in its location. Temporarily install the elbow on the top of the fireplace and, using a level, mark with an oval the location where the flue liner will enter the masonry chimney.
2. In the middle of the oval, drill a hole in the masonry chimney at 45° or 30°.
3. Increase the size of the hole until a 45° or 30° liner elbow can be easily slipped through.
4. Slide the liner down from the top of the masonry chimney until you reach the hole level.
5. Slip through the hole a 45° or 30° liner elbow and connect it to the liner.
6. Add a small liner section to the liner elbow which will allow the liner to extend at least 12" (measured at the top of the liner) from the masonry chimney.
7. Seal the opening around the liner with high temperature refractory cement.
8. Then, follow the chimney manufacturer's instructions to connect the extended liner section to the special chimney connector.

See typical installation illustrated below.

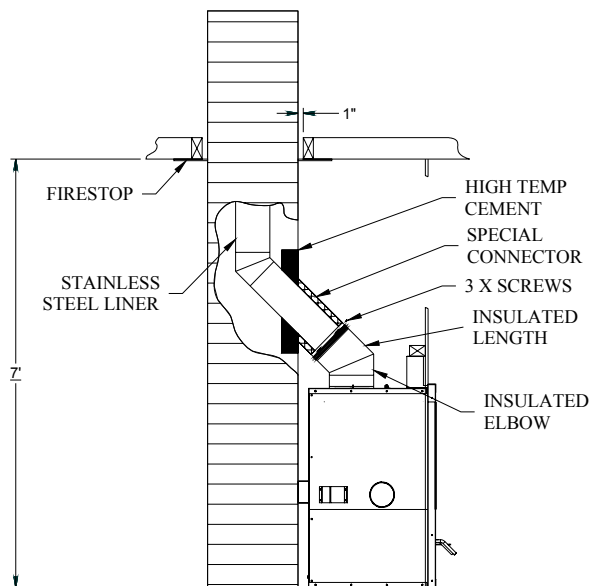

5. OPTIONS

Gravity kit:

Part No.:

Includes: one deflector, two 90° elbows, and two outlet grilles and frames, .

#AC01309

Central forced air kit:

Includes: one blower, one 5" flex adapter, 3 pipe clamps, And one control box with heat sensor and PC Board.

#AC01310

Outside air kit

Includes: one 3" flex adapter, 2 pipe clamps, and one outside wall register.

#AC03500

Rigid fireguard

Includes: one rigid fireguard.

#AC01308

Joist protector

Includes: one joist protector kit*

#AC03510

**May be required if the chimney manufacturer does not supply joist protectors.*

6. APPENDIX

SPECIFICATIONS

Weight: 385 lbs

Height: 38"

Width: 36"

Depth: 26"

CLEARANCE TO COMBUSTIBLES

The following clearances meet the minimum requirements for a safe installation

Side wall: 17" (43 cm) measured from the outside door frame.

Side mantle: 0" (must have a depth no greater than 3").

Ceiling: 7 ft. (2.15 m) measured from the base of the fireplace.

Fireplace enclosure: Bottom: 0"
Side: 0"
Back: 0"
Top: Do not fill the space above the fireplace with any material (except the wood framing).

Chimney: 2" (50 mm)

Combustible shelf : 50" (127 cm) measured from the base of the fireplace for a shelf with a depth of 6" or less.

52" (132 cm) measured from the base of the fireplace for a shelf with a depth of more than 6" (15 cm), but less than 12" (30 cm).

REPLACEMENT PARTS

Description	Part No.	Description	Part No.
Front air tube (1)	PL53030	Bricks (side and rear)	29020
Air tube (2) – second from front	PL53031	Left floor brick	22120
Air tube (3) – third from front	PL53032	Right floor brick	22121
Back air tube (4)	PL53033	Flue insulation collar	21152
Vermiculite baffle	21134	Blowers	44073
Top insulation (2 ½" thick)	21150	Door glass	SE53240
Door gasket	AC06100	Door handle	30560
Glass gasket	AC06400	Air control handle	30561

7. OSBURN LIMITED LIFETIME WARRANTY

The warranty of the manufacturer extends only to the original consumer purchaser and is not transferable. This warranty covers brand new products only, which have not been altered, modified nor repaired since shipment from factory. Proof of purchase (dated bill of sale), model name and serial number must be supplied when making any warranty claim to your OSBURN dealer.

This warranty applies to normal residential use only. Damages caused by misuse, abuse, improper installation, lack of maintenance, over firing, negligence or accident during transportation are not covered by this warranty.

This warranty does not cover any scratch, corrosion or discoloration caused by over firing, abrasives or chemical cleaners. Any defect or damage caused by the use of unauthorized parts or others than original parts void this warranty. An authorized qualified technician must perform the installation in accordance with the Instructions supplied with this product and all local and national building codes. Any service call related to an improper installation is not covered by this warranty.

The manufacturer may require that defective products be returned or that digital pictures be provided to support the claim. Returned products are to be shipped prepaid to the manufacturer for investigation. If a product is found to be defective, the manufacturer will repair or replace such defect and reasonable transportation fees will be refund. Repair work covered by the warranty, executed at the purchaser domicile by an authorized qualified technician requires the prior approval of the manufacturer. Labour cost and repair work to the account of the manufacturer are based on predetermined rate schedule and must not exceed the wholesale price of the replacement part. All labour and freight costs covered by this warranty are limited according to the table below.

The manufacturer at its discretion may decide to repair or replace any part or unit after inspection and investigation of the defect. The manufacturer may, at its discretion, fully discharge all obligations with respect to this warranty by refunding the wholesale price of any warranted but defective parts. The manufacturer shall in no event be responsible for any special, indirect, consequential damages of any nature, which are in excess of the original purchase price of the product.

DESCRIPTION	WARRANTY APPLICATION	
	PARTS	LABOUR & FREIGHT
Combustion chamber (welds only), castings, and convector airmate	Lifetime	5 years
Plating (defective manufacture) – subject to limitations above	Lifetime	n/a
Secondary air tubes, vermiculite baffle, C-Cast baffle and handle assembly	5 years	n/a
Stainless steel baffle and parts	5 years	3 years
Carbon steel baffle and parts	2 years	1 year
Blowers, thermal switches, rheostat, and other controls	2 years	1 year
Paint, refractory bricks, gasket, ceramic blankets, and ceramic glass (thermal breakage only)	1 year	n/a

Shall your unit or a components be defective, contact immediately your **OSBURN** dealer. Prior to your call make sure you have the following information necessary to your warranty claim treatment:

- You name, address and telephone number;
- Bill of sale and dealer's name;
- Serial number and model name as indicated on the nameplate fixed to the back of your unit;
- Nature of the defect and any relevant information.

Before shipping your unit or defective component to our plant, you must obtain from your OSBURN dealer an Authorization Number. Any merchandise shipped to our plant without authorization will be refused automatically and returned to sender.